



**McGuire Manufacturing Co., Inc.**

60 Grandview Court  
 Cheshire, Connecticut 06410  
 (203) 699-1801 Fax (203) 699-1813  
 customerservice@mcguiremfg.com mcguiremfg.com

**PRODUCT SPECIFICATION**

**Part No.**

**8089CBOS6**

**Boston Sweat P-Trap**

**Job Name:**

**Submittal Number:**

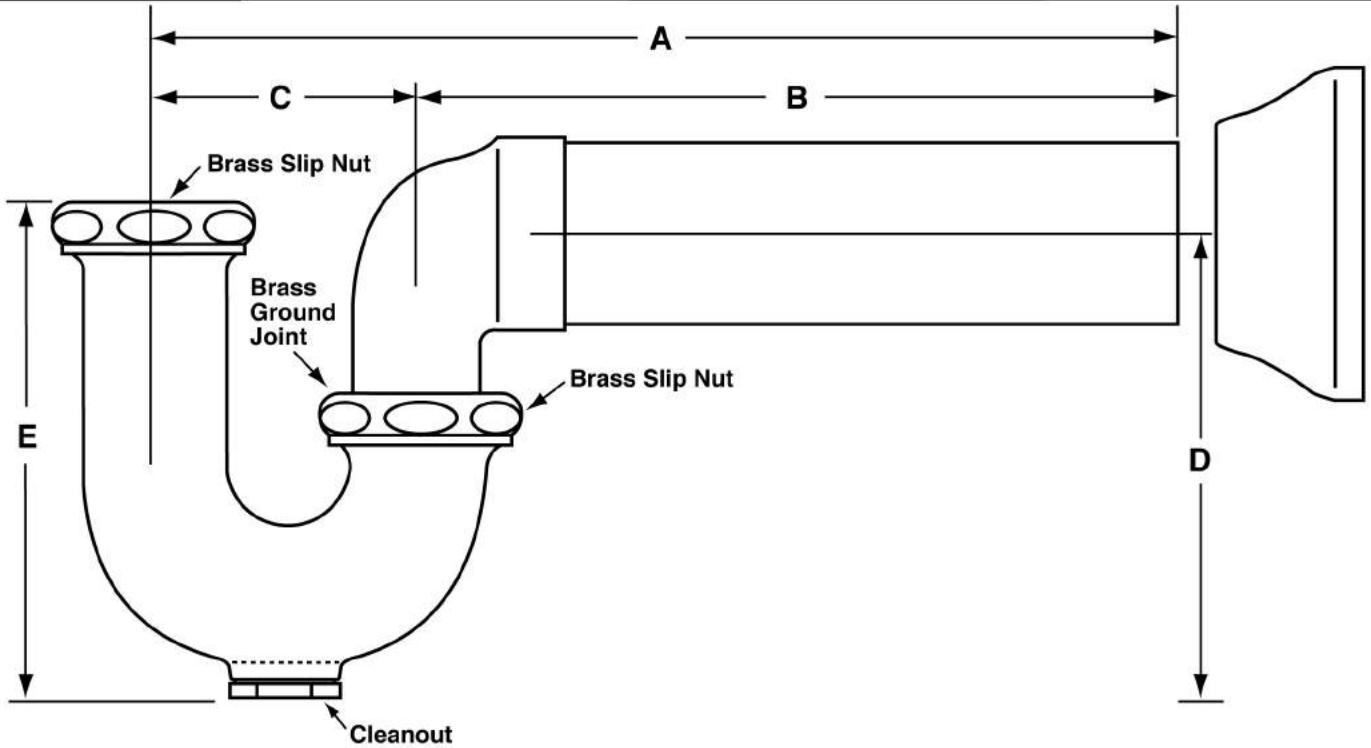

**ROUGHING MEASUREMENTS**

NO.	TRAP DIMENSIONS		A	B	C	D	E
	INLET	OUTLET					
8089CBOS6	1-1/2"	1-1/2" w/6" Sweat Extension	10"	7"	3"	4-1/2"	5"

Note: Minimum seal 2"

See options and accessories section for details on product variations.



ASME A112.18.2/CSA B125.2

**Specifications:**

P-Trap shall be chrome plated cast brass body with cleanout, 17 gauge seamless tubular sweat extension, cast brass ground joint elbow, and cast brass slip nuts. No reducing washers. With (shallow, deep, bell) (steel, brass) or (forged brass with set screw) flange.



**WARNING:**

This product can expose you to chemicals including lead, which is known to the State of California to cause cancer, and birth defects or other reproductive harm. For more information go to [www.P65Warnings.ca.gov](http://www.P65Warnings.ca.gov).



**McGuire Manufacturing Co., Inc.**

60 Grandview Court

Cheshire, Connecticut 06410

(203) 699-1801 Fax (203) 699-1813

customerservice@mcguiremfg.com mcguiremfg.com

**PRODUCT SPECIFICATION**

**Part No.**

**8089CBOS12**

**Boston Sweat P-Trap**

**Job Name:**

**Submittal Number:**

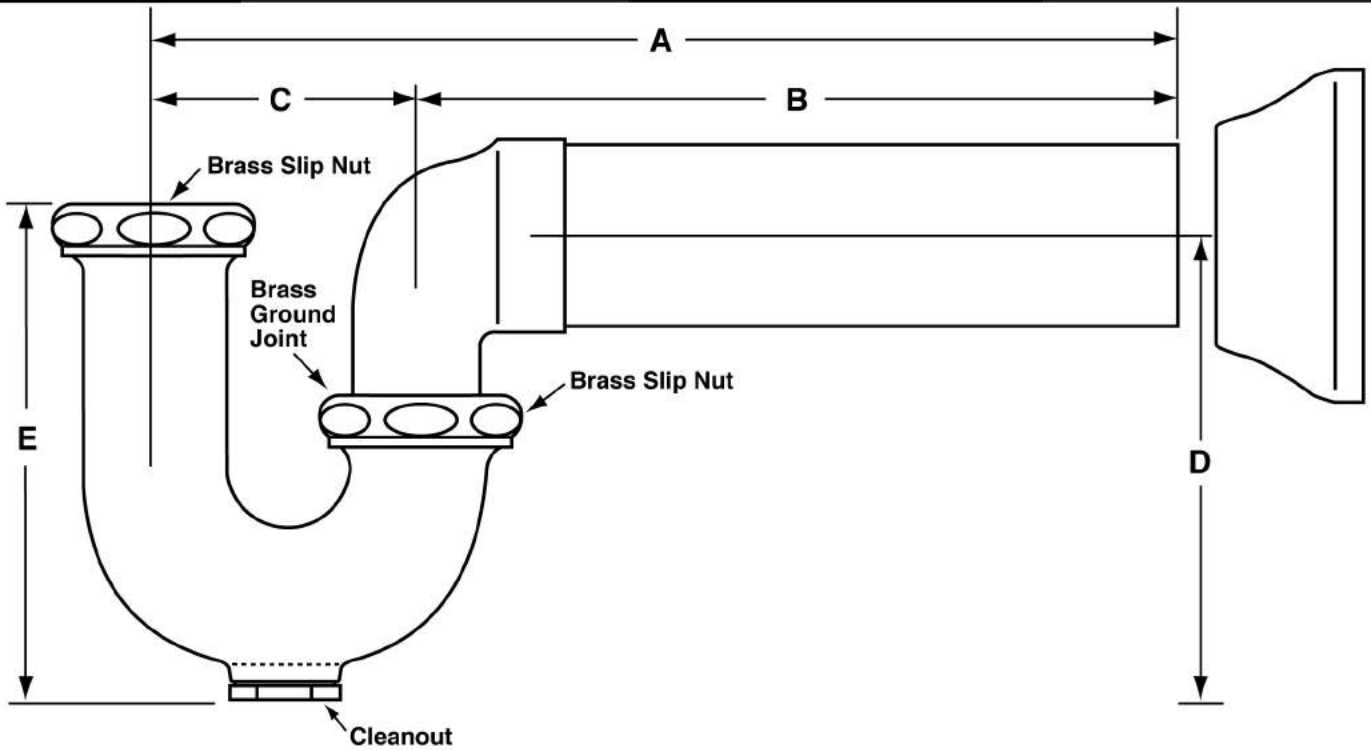

**ROUGHING MEASUREMENTS**

NO.	TRAP DIMENSIONS		A	B	C	D	E
	INLET	OUTLET					
8089CBOS12	1-1/2"	1-1/2" w/12" Sweat Extension	16"	13"	3"	4-1/2"	5"

Note: Minimum seal 2"

See options and accessories section for details on product variations.



ASME A112.18.2/CSA B125.2

**Specifications:**

P-Trap shall be chrome plated cast brass body with cleanout, 17 gauge seamless tubular sweat extension, cast brass ground joint elbow, and cast brass slip nuts. No reducing washers. With (shallow, deep, bell) (steel, brass) or (forged brass with set screw) flange.



**WARNING:**

This product can expose you to chemicals including lead, which is known to the State of California to cause cancer, and birth defects or other reproductive harm. For more information go to [www.P65Warnings.ca.gov](http://www.P65Warnings.ca.gov).



**McGuire Manufacturing Co., Inc.**

60 Grandview Court  
 Cheshire, Connecticut 06410  
 (203) 699-1801 Fax (203) 699-1813  
 customerservice@mcguiremfg.com mcguiremfg.com

**PRODUCT SPECIFICATION**

**Part No.**

**8090CBOS6**

**Boston Sweat P-Trap**

**Job Name:**

**Submittal Number:**

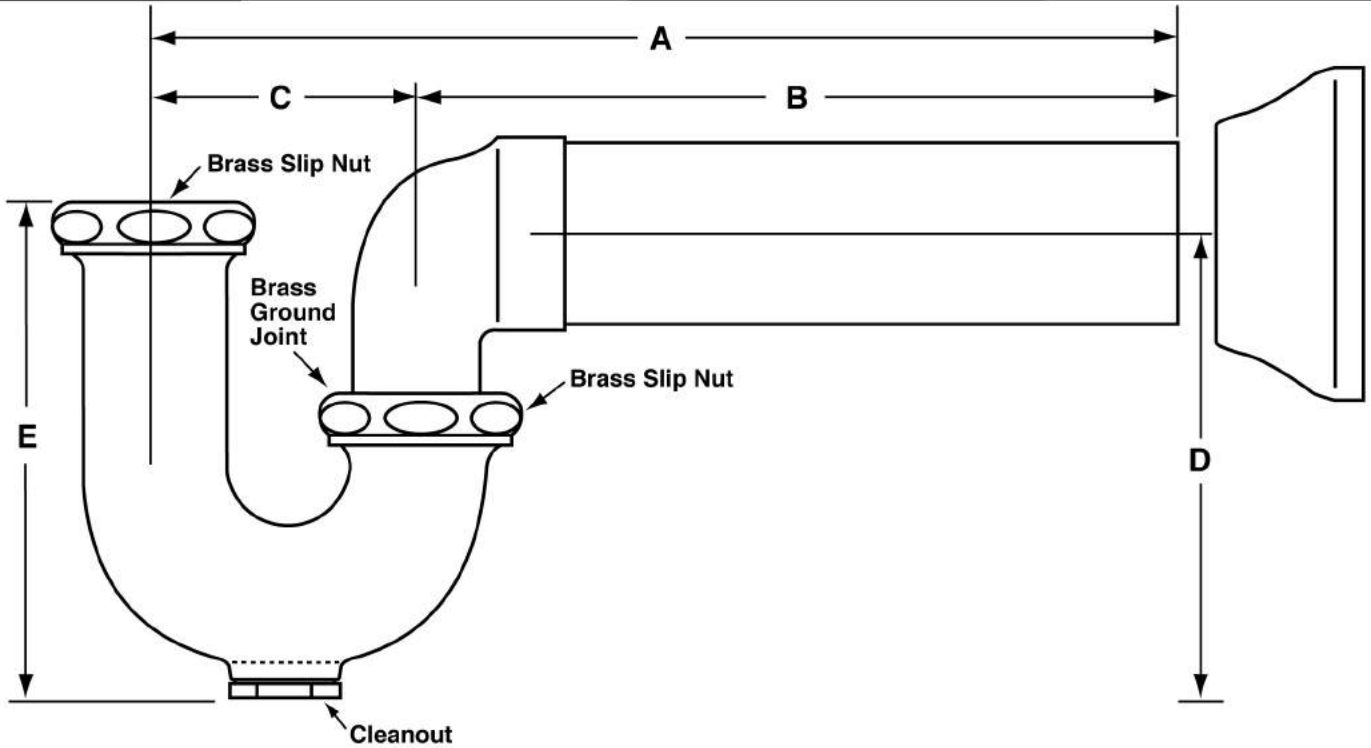

**ROUGHING MEASUREMENTS**

NO.	TRAP DIMENSIONS		A	B	C	D	E
	INLET	OUTLET					
8090CBOS6	1-1/4"	1-1/2" w/6" Sweat Extension	10"	7"	3"	4-1/2"	5"

Note: Minimum seal 2"

See options and accessories section for details on product variations.



ASME A112.18.2/CSA B125.2

**Specifications:**

P-Trap shall be chrome plated cast brass body with cleanout, 17 gauge seamless tubular sweat extension, cast brass ground joint elbow, and cast brass slip nuts. No reducing washers. With (shallow, deep, bell) (steel, brass) or (forged brass with set screw) flange.



**WARNING:**

This product can expose you to chemicals including lead, which is known to the State of California to cause cancer, and birth defects or other reproductive harm. For more information go to [www.P65Warnings.ca.gov](http://www.P65Warnings.ca.gov).



**McGuire Manufacturing Co., Inc.**

60 Grandview Court  
 Cheshire, Connecticut 06410  
 (203) 699-1801 Fax (203) 699-1813  
 customerservice@mcguiremfg.com mcguiremfg.com

**PRODUCT SPECIFICATION**

**Part No.**

**8090CBOS12**

**Boston Sweat P-Trap**

**Job Name:**

**Submittal Number:**

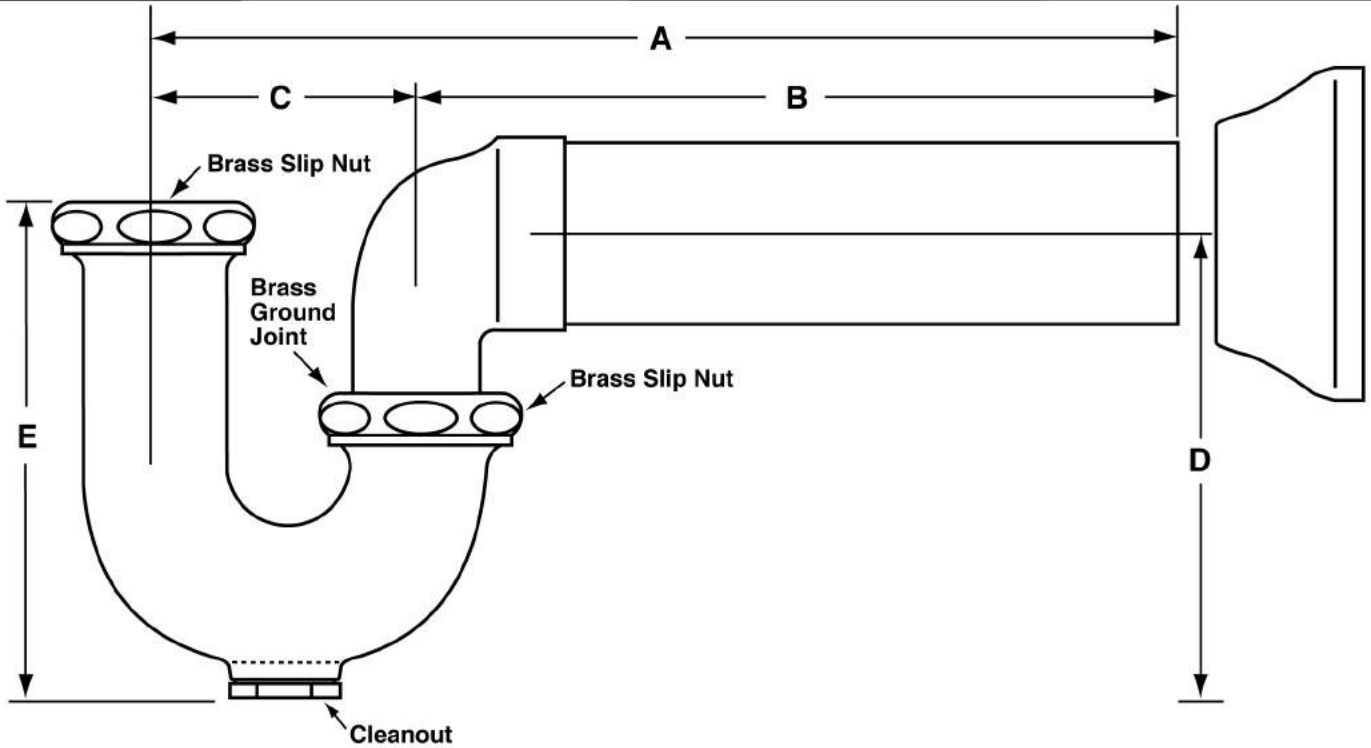

**ROUGHING MEASUREMENTS**

NO.	TRAP DIMENSIONS		A	B	C	D	E
	INLET	OUTLET					
8090CBOS12	1-1/4"	1-1/2" w/12" Sweat Extension	16"	13"	3"	4-1/2"	5"

Note: Minimum seal 2"

See options and accessories section for details on product variations.



ASME A112.18.2/CSA B125.2

**Specifications:**

P-Trap shall be chrome plated cast brass body with cleanout, 17 gauge seamless tubular sweat extension, cast brass ground joint elbow, and cast brass slip nuts. No reducing washers. With (shallow, deep, bell) (steel, brass) or (forged brass with set screw) flange.



**WARNING:**

This product can expose you to chemicals including lead, which is known to the State of California to cause cancer, and birth defects or other reproductive harm. For more information go to [www.P65Warnings.ca.gov](http://www.P65Warnings.ca.gov).



# McGuire Manufacturing Co., Inc.

60 Grandview Court  
 Cheshire, Connecticut 06410  
 (203) 699-1801 Fax (203) 699-1813  
 customerservice@mcguiremfg.com mcguiremfg.com

## PRODUCT SPECIFICATION

**Part No.**

**8872C**

**Cast Body P-Trap  
 With or Without Cleanout**

**Job Name:**

**Submittal Number:**

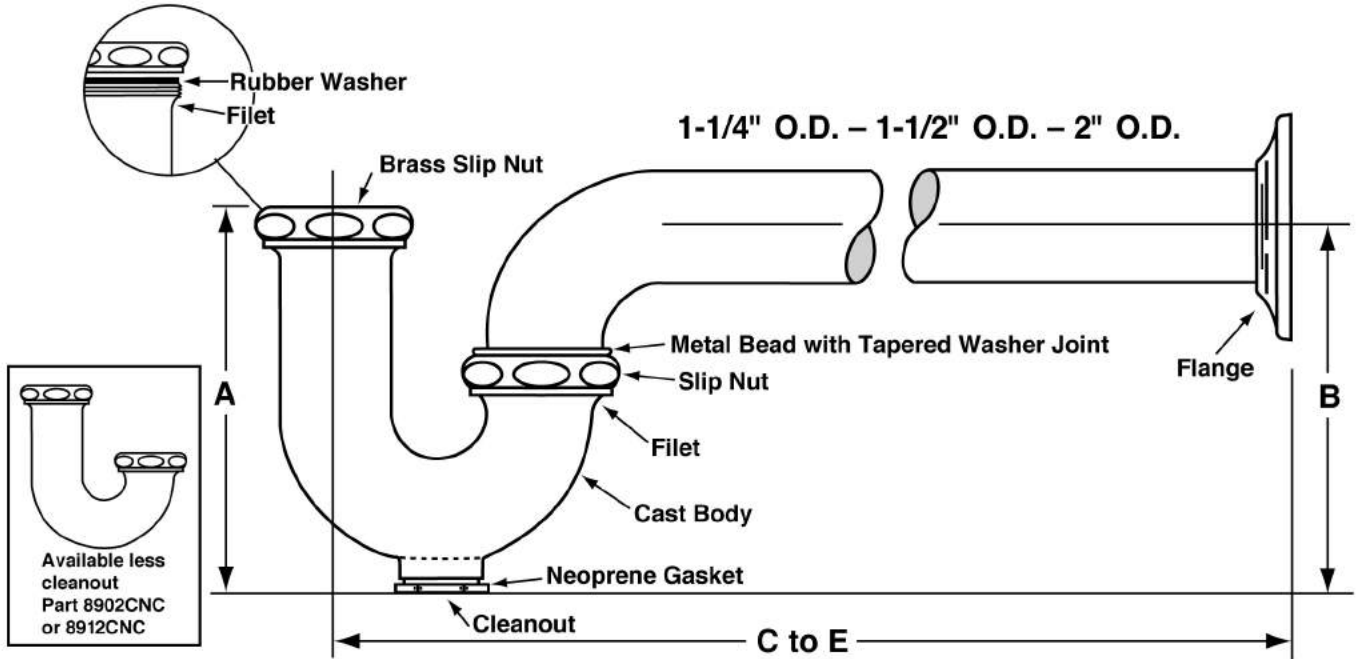

### PROFESSIONAL LINE

#### ROUGHING MEASUREMENTS

NO.	TRAP DIMENSIONS		A	B	C to E
	INLET	OUTLET			
8872C	1-1/4"	1-1/4"	4-1/2"	4-1/4"	11-1/2"

- Rated Operating Temperature: 40-140°F
- Note: 180°F max. during temporary high-temperature system flush

**FED SPEC W.W.P. 541  
 CAST BRASS P TRAP  
 MINIMUM SEAL 2"**



See options and accessories section for details on product variations.

ASME A112.18.2/CSA B125-2

### Specifications:

P-Trap shall be chrome plated cast brass body (with, without) cleanout, with 17 gauge seamless tubular wall bend, cast brass slip nuts. Reducing washers shall be used with reducing cast brass nut. With (shallow, deep, bell) (steel, brass) or (forged brass with set screw) flange.

P-Trap shall be McGuire "Classic" Professional Line

Trap shall be certified by CSA or other recognized testing authority. Trap shall bear manufacturer and testing marks.

**! WARNING:**

This product can expose you to chemicals including lead, which is known to the State of California to cause cancer, and birth defects or other reproductive harm. For more information go to [www.P65Warnings.ca.gov](http://www.P65Warnings.ca.gov).



**McGuire Manufacturing Co., Inc.**

60 Grandview Court  
 Cheshire, Connecticut 06410  
 (203) 699-1801 Fax (203) 699-1813  
 customerservice@mcguiremfg.com mcguiremfg.com

**Part No.**

**8872CBECO**

**Cast Body P-Trap With  
 or Without Cleanout**

**PRODUCT SPECIFICATION**

**Job Name:**

**Submittal Number:**

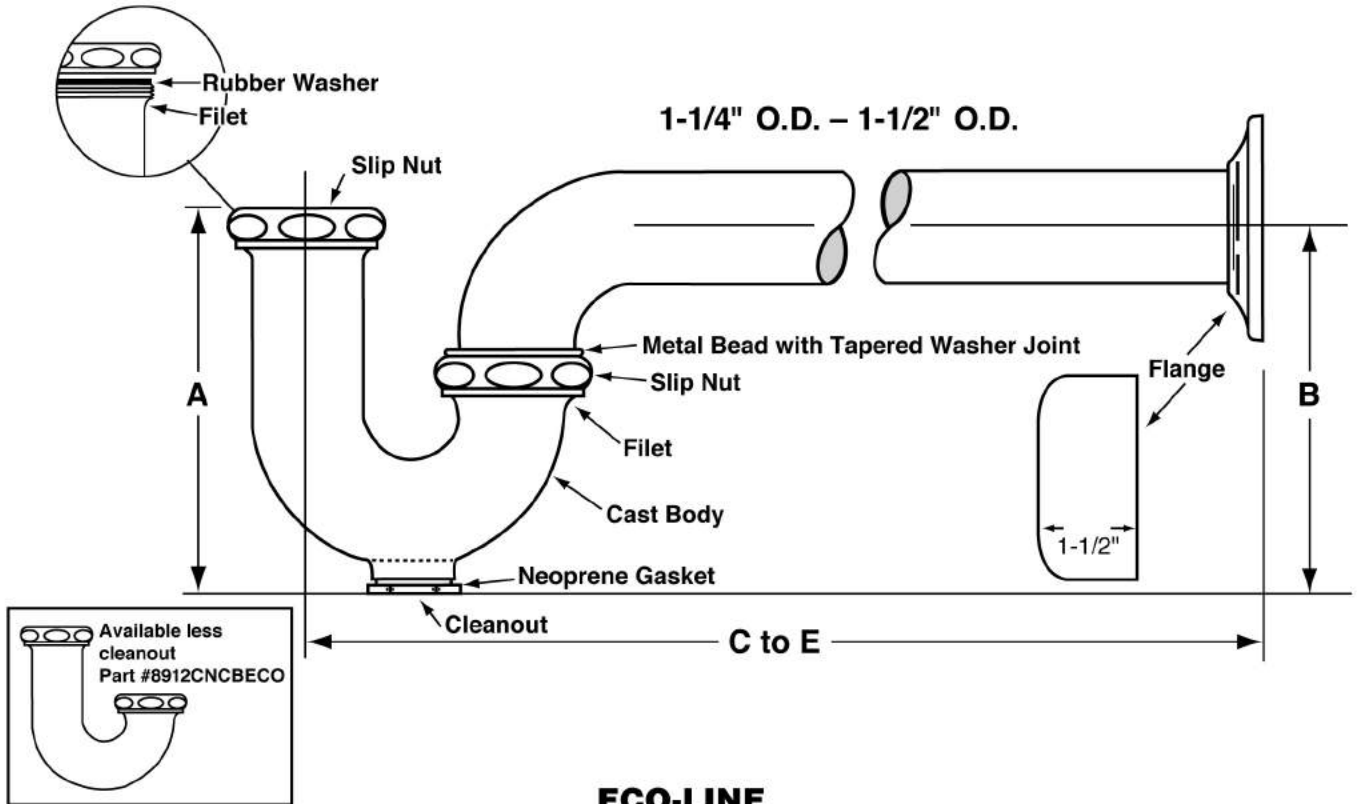

**ECO-LINE**

**ROUGHING MEASUREMENTS**

MODEL NO.	TRAP DIMENSIONS		A	B	C to E	FLANGE	SLIP NUT
	INLET	OUTLET					
8872CBECO	1-1/4"	1-1/4"	4-1/2"	4-1/2"	11"	Box	Brass

**FED SPEC W.W.P. 541  
 CAST BRASS P-TRAP  
 MINIMUM SEAL 2"**



ASME A112.18.2/CSA B125.2

**Specifications:**

Chrome plated P-Trap shall be cast brass body, with or without cleanout, with 17 gauge seamless tubular wall bend and flange.



**WARNING:**

This product can expose you to chemicals including lead, which is known to the State of California to cause cancer, and birth defects or other reproductive harm. For more information go to [www.P65Warnings.ca.gov](http://www.P65Warnings.ca.gov).



# McGuire Manufacturing Co., Inc.

60 Grandview Court  
 Cheshire, Connecticut 06410  
 (203) 699-1801 Fax (203) 699-1813  
 customerservice@mcguiremfg.com mcguiremfg.com

## PRODUCT SPECIFICATION

**Part No.**

**8902C**

**Cast Body P-Trap  
 With or Without Cleanout**

**Job Name:**

**Submittal Number:**

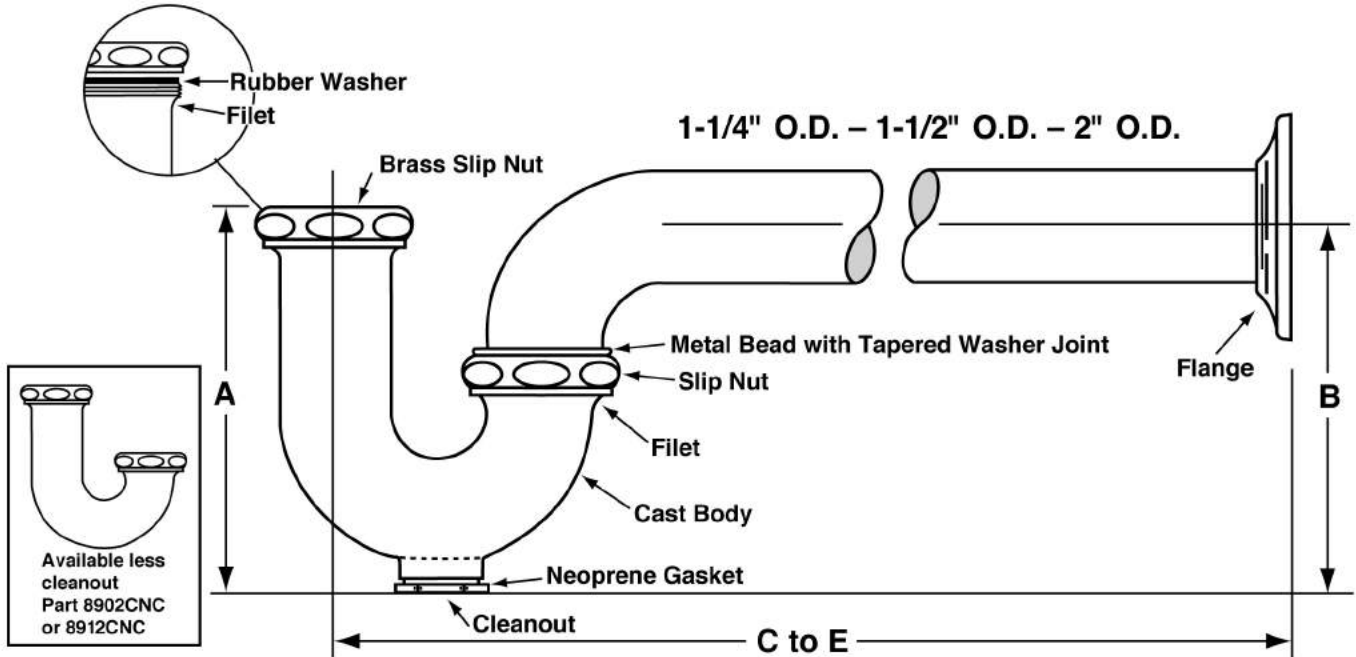

### PROFESSIONAL LINE

#### ROUGHING MEASUREMENTS

NO.	TRAP DIMENSIONS		A	B	C to E
	INLET	OUTLET			
8902 C	1-1/4"	1-1/2"	5"	5-1/2"	11-1/2"

**FED SPEC W.W.P. 541  
 CAST BRASS P TRAP  
 MINIMUM SEAL 2"**



See options and accessories section for details on product variations.

ASME A112.18.2/CSA B125-2

## Specifications:

P-Trap shall be chrome plated cast brass body (with, without) cleanout, with 17 gauge seamless tubular wall bend, cast brass slip nuts. Reducing washers shall be used with reducing cast brass nut. With (shallow, deep, bell) (steel, brass) or (forged brass with set screw) flange.

P-Trap shall be McGuire "Classic" Professional Line

Trap shall be certified by CSA or other recognized testing authority. Trap shall bear manufacturer and testing marks.

**! WARNING:**

This product can expose you to chemicals including lead, which is known to the State of California to cause cancer, and birth defects or other reproductive harm. For more information go to [www.P65Warnings.ca.gov](http://www.P65Warnings.ca.gov).



# McGuire Manufacturing Co., Inc.

60 Grandview Court  
 Cheshire, Connecticut 06410  
 (203) 699-1801 Fax (203) 699-1813  
 customerservice@mcguiremfg.com mcguiremfg.com

## PRODUCT SPECIFICATION

**Part No.**

**8902CNC**

**Cast Body P-Trap  
 With or Without Cleanout**

**Job Name:**

**Submittal Number:**

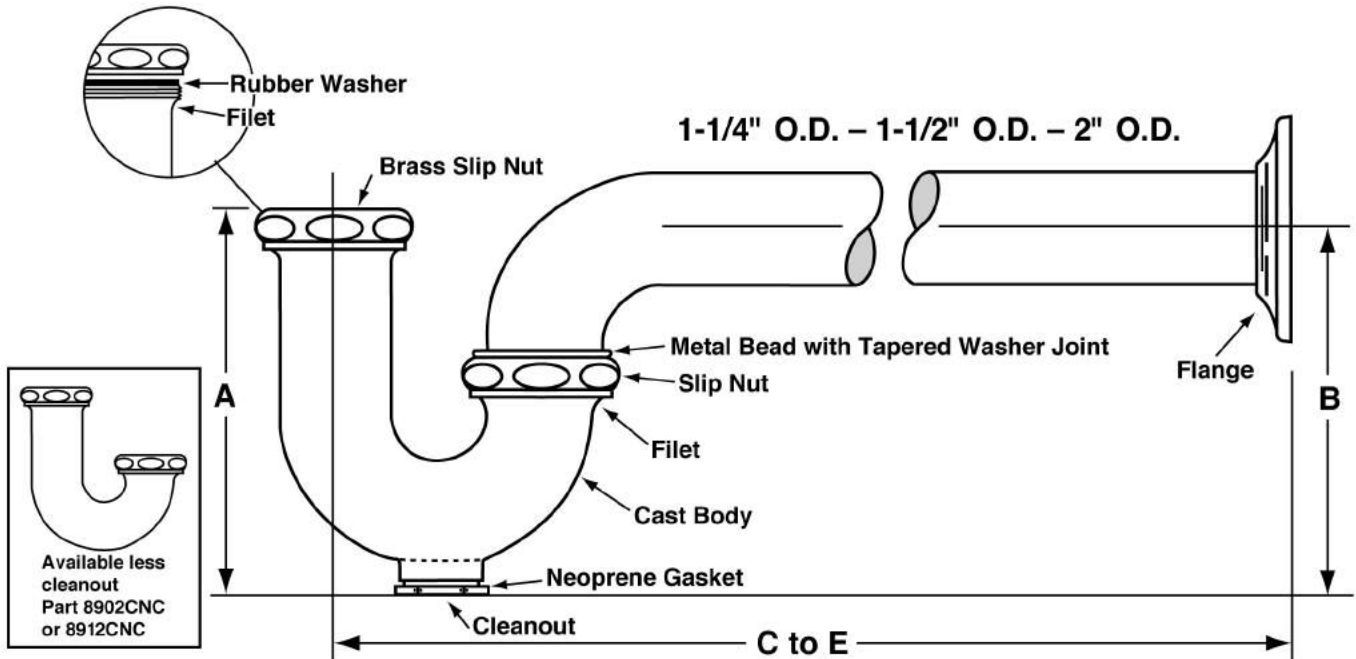

### PROFESSIONAL LINE

#### ROUGHING MEASUREMENTS

NO.	TRAP DIMENSIONS		A	B	C to E
	INLET	OUTLET			
8902CNC	1-1/4"	1-1/2"	4-5/8"	4-3/4"	11-1/2"

**FED SPEC W.W.P. 541  
 CAST BRASS P TRAP  
 MINIMUM SEAL 2"**



See options and accessories section for details on product variations.

ASME A112.18.2/CSA B125-2

## Specifications:

P-Trap shall be chrome plated cast brass body (with, without) cleanout, with 17 gauge seamless tubular wall bend, cast brass slip nuts. Reducing washers shall be used with reducing cast brass nut. With (shallow, deep, bell) (steel, brass) or (forged brass with set screw) flange.

P-Trap shall be McGuire "Classic" Professional Line

Trap shall be certified by CSA or other recognized testing authority. Trap shall bear manufacturer and testing marks.

**! WARNING:**

This product can expose you to chemicals including lead, which is known to the State of California to cause cancer, and birth defects or other reproductive harm. For more information go to [www.P65Warnings.ca.gov](http://www.P65Warnings.ca.gov).





# McGuire Manufacturing Co., Inc.

60 Grandview Court  
 Cheshire, Connecticut 06410  
 (203) 699-1801 Fax (203) 699-1813  
 customerservice@mcguiremfg.com mcguiremfg.com

## PRODUCT SPECIFICATION

**Part No.**

**8903C**

**Cast Body P-Trap  
 With or Without Cleanout**

**Job Name:**

**Submittal Number:**

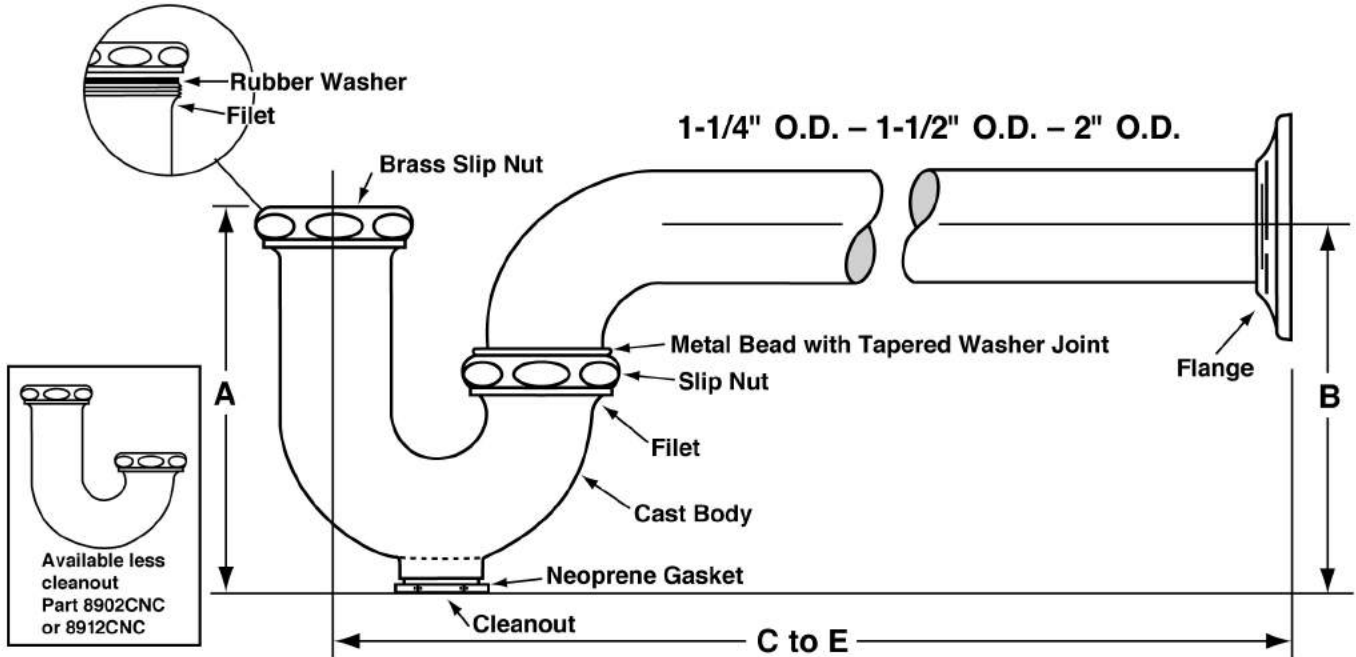

### PROFESSIONAL LINE

#### ROUGHING MEASUREMENTS

NO.	TRAP DIMENSIONS		A	B	C to E
	INLET	OUTLET			
8903C	1-1/2"	2"	5"	6"	13-3/4"

**FED SPEC W.W.P. 541  
 CAST BRASS P TRAP  
 MINIMUM SEAL 2"**

See options and accessories section for details on product variations.

ASME A112.18.2/CSA B125-2



## Specifications:

P-Trap shall be chrome plated cast brass body (with, without) cleanout, with 17 gauge seamless tubular wall bend, cast brass slip nuts. Reducing washers shall be used with reducing cast brass nut. With (shallow, deep, bell) (steel, brass) or (forged brass with set screw) flange.

P-Trap shall be McGuire "Classic" Professional Line

Trap shall be certified by CSA or other recognized testing authority. Trap shall bear manufacturer and testing marks.



### WARNING:

This product can expose you to chemicals including lead, which is known to the State of California to cause cancer, and birth defects or other reproductive harm. For more information go to [www.P65Warnings.ca.gov](http://www.P65Warnings.ca.gov).



# McGuire Manufacturing Co., Inc.

60 Grandview Court  
 Cheshire, Connecticut 06410  
 (203) 699-1801 Fax (203) 699-1813  
 customerservice@mcguiremfg.com mcguiremfg.com

## PRODUCT SPECIFICATION

**Part No.**

**8904C**

**Cast Body P-Trap  
 With or Without Cleanout**

**Job Name:**

**Submittal Number:**

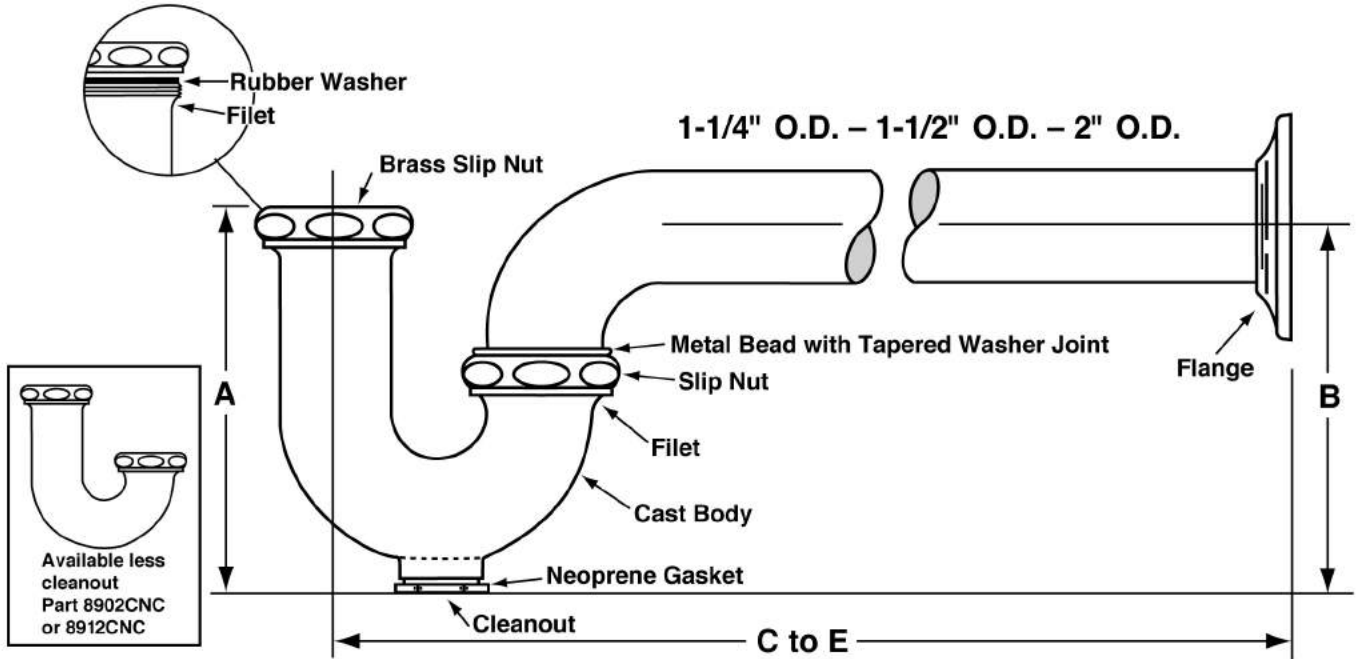

### PROFESSIONAL LINE

#### ROUGHING MEASUREMENTS

NO.	TRAP DIMENSIONS		A	B	C to E
	INLET	OUTLET			
8904C	2"	2"	5"	6"	13-3/4"

**FED SPEC W.W.P. 541  
 CAST BRASS P TRAP  
 MINIMUM SEAL 2"**

See options and accessories section for details on product variations.

ASME A112.18.2/CSA B125-2



## Specifications:

P-Trap shall be chrome plated cast brass body (with, without) cleanout, with 17 gauge seamless tubular wall bend, cast brass slip nuts. Reducing washers shall be used with reducing cast brass nut. With (shallow, deep, bell) (steel, brass) or (forged brass with set screw) flange.

P-Trap shall be McGuire "Classic" Professional Line

Trap shall be certified by CSA or other recognized testing authority. Trap shall bear manufacturer and testing marks.



**WARNING:**

This product can expose you to chemicals including lead, which is known to the State of California to cause cancer, and birth defects or other reproductive harm. For more information go to [www.P65Warnings.ca.gov](http://www.P65Warnings.ca.gov).



**McGuire Manufacturing Co., Inc.**

60 Grandview Court  
 Cheshire, Connecticut 06410  
 (203) 699-1801 Fax (203) 699-1813  
 customerservice@mcguiremfg.com mcguiremfg.com

**Part No.**

**8904CBECO**

**Cast Body P-Trap With  
 or Without Cleanout**

**PRODUCT SPECIFICATION**

**Job Name:**

**Submittal Number:**

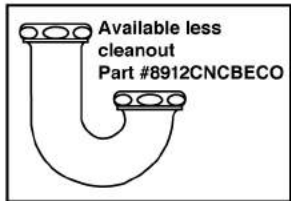
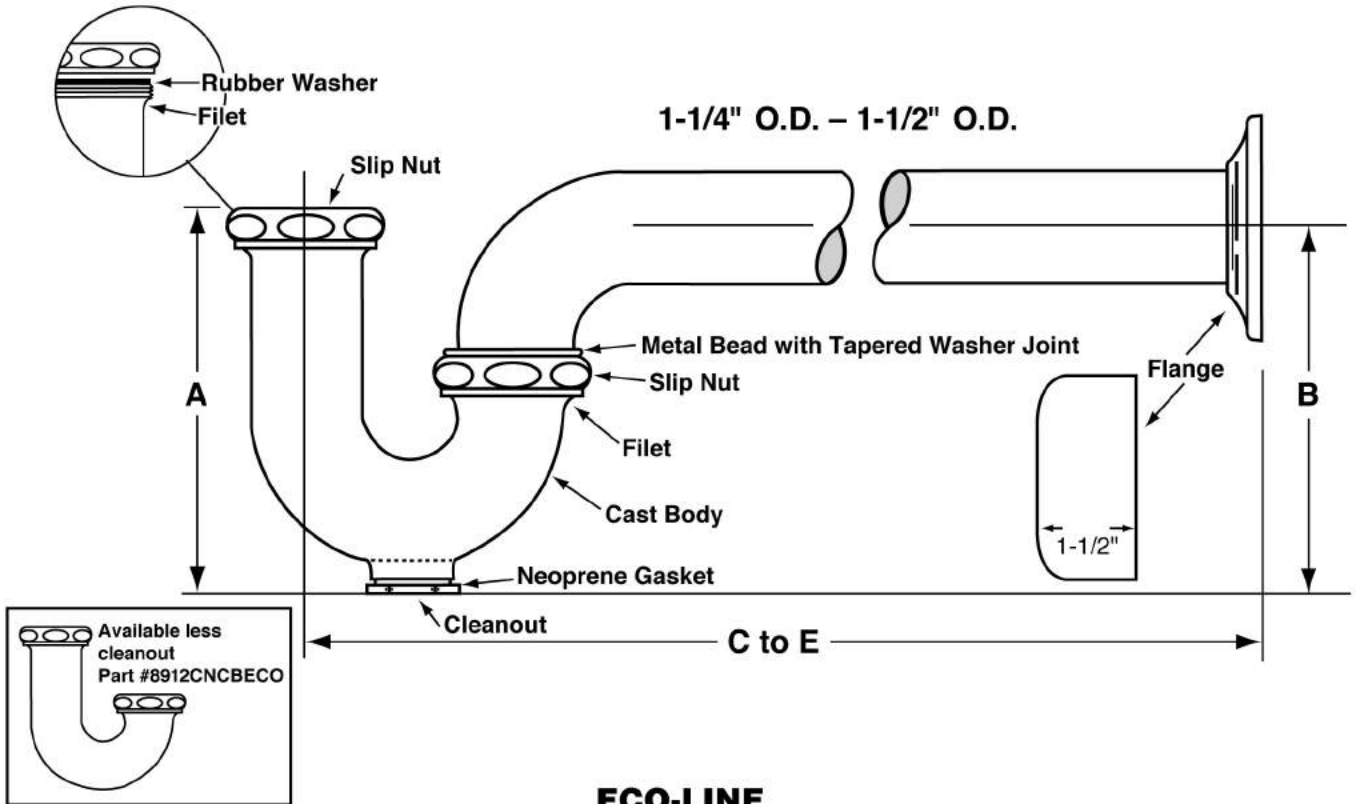

**ECO-LINE**

**ROUGHING MEASUREMENTS**

MODEL NO.	TRAP DIMENSIONS		A	B	C to E	FLANGE	SLIP NUT
	INLET	OUTLET					
8904CBECO	1-1/2", 2"	2"	5"	6"	13-1/2"	Box	Brass

**FED SPEC W.W.P. 541  
 CAST BRASS P-TRAP  
 MINIMUM SEAL 2"**



ASME A112.18.2/CSA B125.2

**Specifications:**

Chrome plated P-Trap shall be cast brass body, with or without cleanout, with 17 gauge seamless tubular wall bend and flange.



**WARNING:**

This product can expose you to chemicals including lead, which is known to the State of California to cause cancer, and birth defects or other reproductive harm. For more information go to [www.P65Warnings.ca.gov](http://www.P65Warnings.ca.gov).



# McGuire Manufacturing Co., Inc.

60 Grandview Court  
 Cheshire, Connecticut 06410  
 (203) 699-1801 Fax (203) 699-1813  
 customerservice@mcguiremfg.com mcguiremfg.com

## PRODUCT SPECIFICATION

**Part No.**

**8912C**

**Cast Body P-Trap  
 With or Without Cleanout**

**Job Name:**

**Submittal Number:**

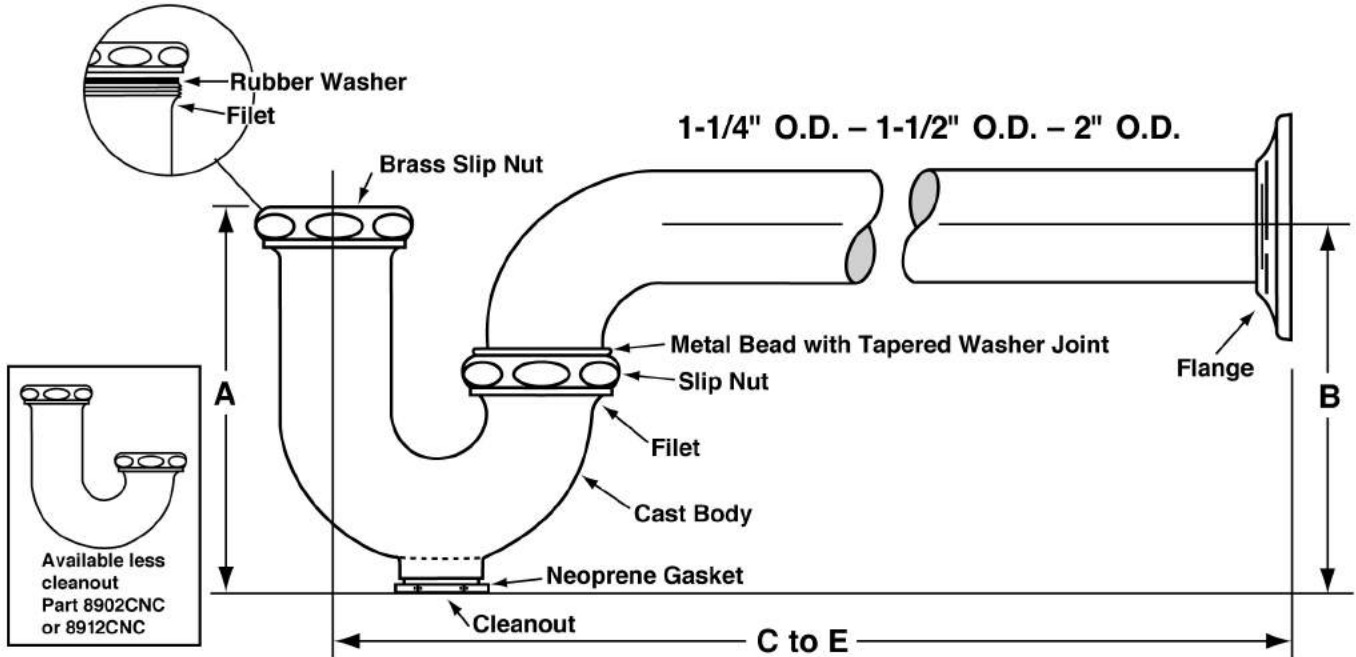

### PROFESSIONAL LINE

#### ROUGHING MEASUREMENTS

NO.	TRAP DIMENSIONS		A	B	C to E
	INLET	OUTLET			
8912C	1-1/2"	1-1/2"	5"	5-1/2"	11-1/2"

- Rated Operating Temperature: 40-140°F
- Note: 180°F max. during temporary high-temperature system flush

**FED SPEC W.W.P. 541  
 CAST BRASS P TRAP  
 MINIMUM SEAL 2"**



See options and accessories section for details on product variations.

ASME A112.18.2/CSA B125-2

## Specifications:

P-Trap shall be chrome plated cast brass body (with, without) cleanout, with 17 gauge seamless tubular wall bend, cast brass slip nuts. Reducing washers shall be used with reducing cast brass nut. With (shallow, deep, bell) (steel, brass) or (forged brass with set screw) flange.

P-Trap shall be McGuire "Classic" Professional Line

Trap shall be certified by CSA or other recognized testing authority. Trap shall bear manufacturer and testing marks.



### WARNING:

This product can expose you to chemicals including lead, which is known to the State of California to cause cancer, and birth defects or other reproductive harm. For more information go to [www.P65Warnings.ca.gov](http://www.P65Warnings.ca.gov).



**McGuire Manufacturing Co., Inc.**

60 Grandview Court  
 Cheshire, Connecticut 06410  
 (203) 699-1801 Fax (203) 699-1813  
 customerservice@mcguiremfg.com mcguiremfg.com

**Part No.**

**8912C18BECO**

**Cast Body P-Trap With  
 or Without Cleanout**

**PRODUCT SPECIFICATION**

**Job Name:**

**Submittal Number:**

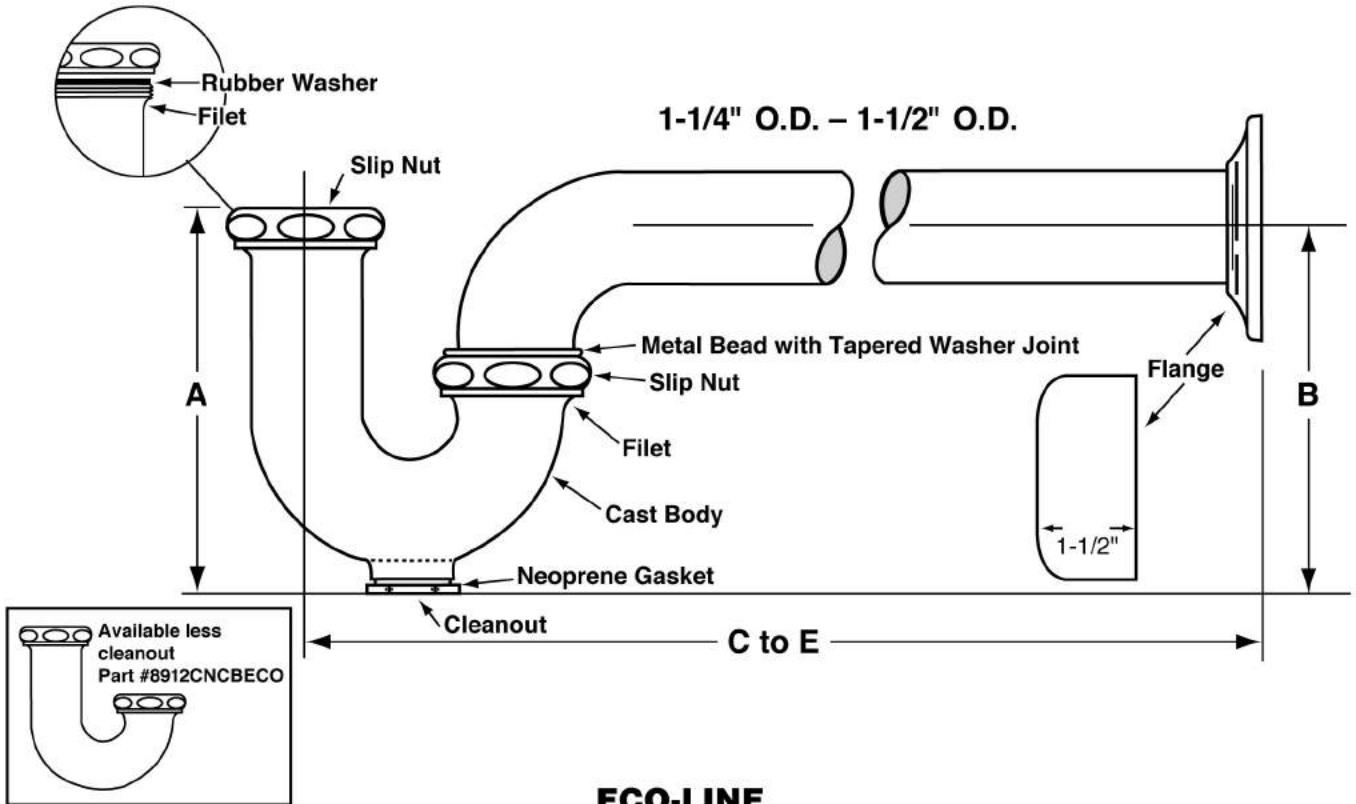

**ECO-LINE**

**ROUGHING MEASUREMENTS**

MODEL NO.	TRAP DIMENSIONS		A	B	C to E	FLANGE	SLIP NUT
	INLET	OUTLET					
8912C18BECO	1-1/2", 1-1/4"	1-1/2"	5"	5"	18"	Box	Brass

**FED SPEC W.W.P. 541  
 CAST BRASS P-TRAP  
 MINIMUM SEAL 2"**



ASME A112.18.2/CSA B125.2

**Specifications:**

Chrome plated P-Trap shall be cast brass body, with or without cleanout, with 17 gauge seamless tubular wall bend and flange.



**WARNING:**

This product can expose you to chemicals including lead, which is known to the State of California to cause cancer, and birth defects or other reproductive harm. For more information go to [www.P65Warnings.ca.gov](http://www.P65Warnings.ca.gov).



**McGuire Manufacturing Co., Inc.**

60 Grandview Court  
 Cheshire, Connecticut 06410  
 (203) 699-1801 Fax (203) 699-1813  
 customerservice@mcguiremfg.com mcguiremfg.com

**Part No.**

**8912CBECO**

**Cast Body P-Trap With  
 or Without Cleanout**

**PRODUCT SPECIFICATION**

**Job Name:**

**Submittal Number:**

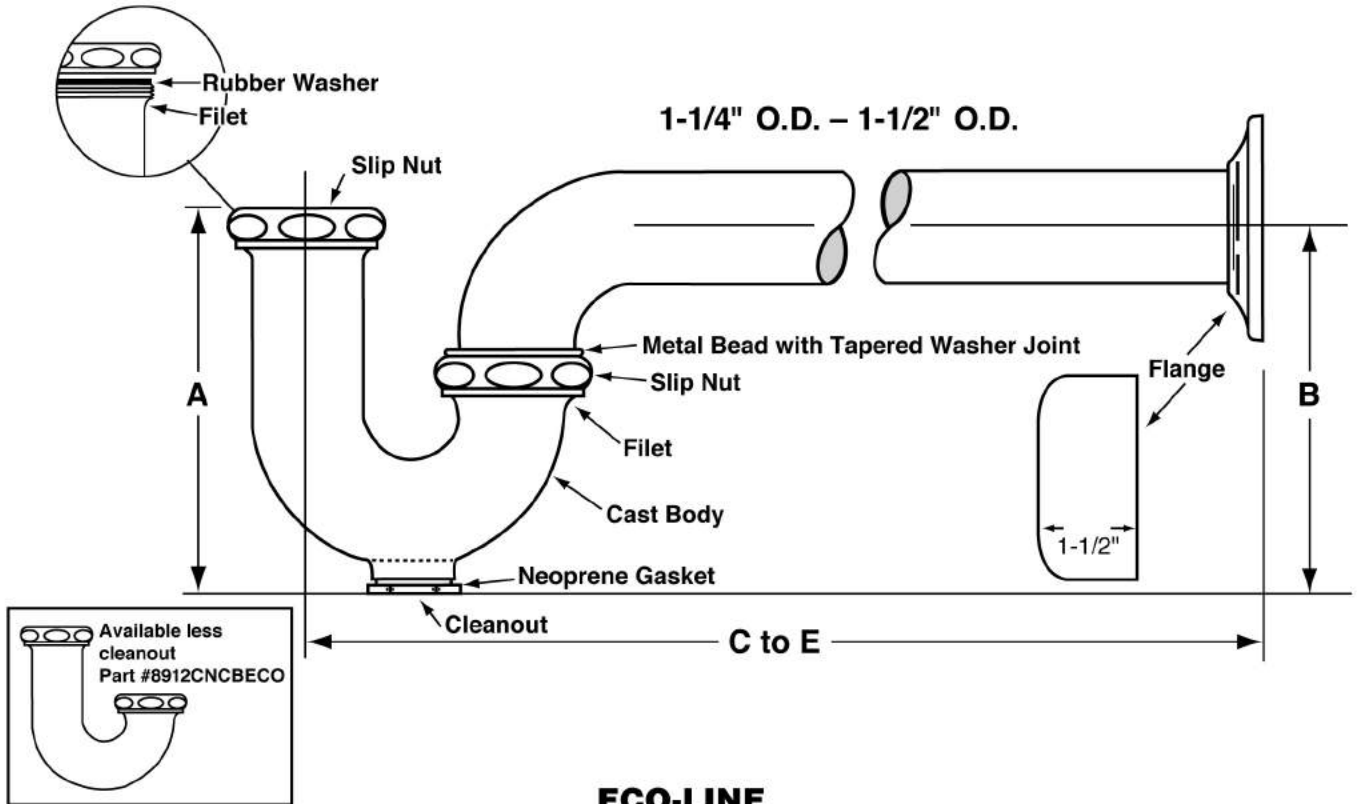

**ECO-LINE**

**ROUGHING MEASUREMENTS**

MODEL NO.	TRAP DIMENSIONS		A	B	C to E	FLANGE	SLIP NUT
	INLET	OUTLET					
8912CBECO	1-1/2", 1-1/4"	1-1/2"	5"	5"	12"	Box	Brass

**FED SPEC W.W.P. 541  
 CAST BRASS P-TRAP  
 MINIMUM SEAL 2"**



ASME A112.18.2/CSA B125.2

**Specifications:**

Chrome plated P-Trap shall be cast brass body, with or without cleanout, with 17 gauge seamless tubular wall bend and flange.



**WARNING:**

This product can expose you to chemicals including lead, which is known to the State of California to cause cancer, and birth defects or other reproductive harm. For more information go to [www.P65Warnings.ca.gov](http://www.P65Warnings.ca.gov).



# McGuire Manufacturing Co., Inc.

60 Grandview Court  
 Cheshire, Connecticut 06410  
 (203) 699-1801 Fax (203) 699-1813  
 customerservice@mcguiremfg.com mcguiremfg.com

## PRODUCT SPECIFICATION

**Part No.**

**8912CNC**

**Cast Body P-Trap  
 With or Without Cleanout**

**Job Name:**

**Submittal Number:**

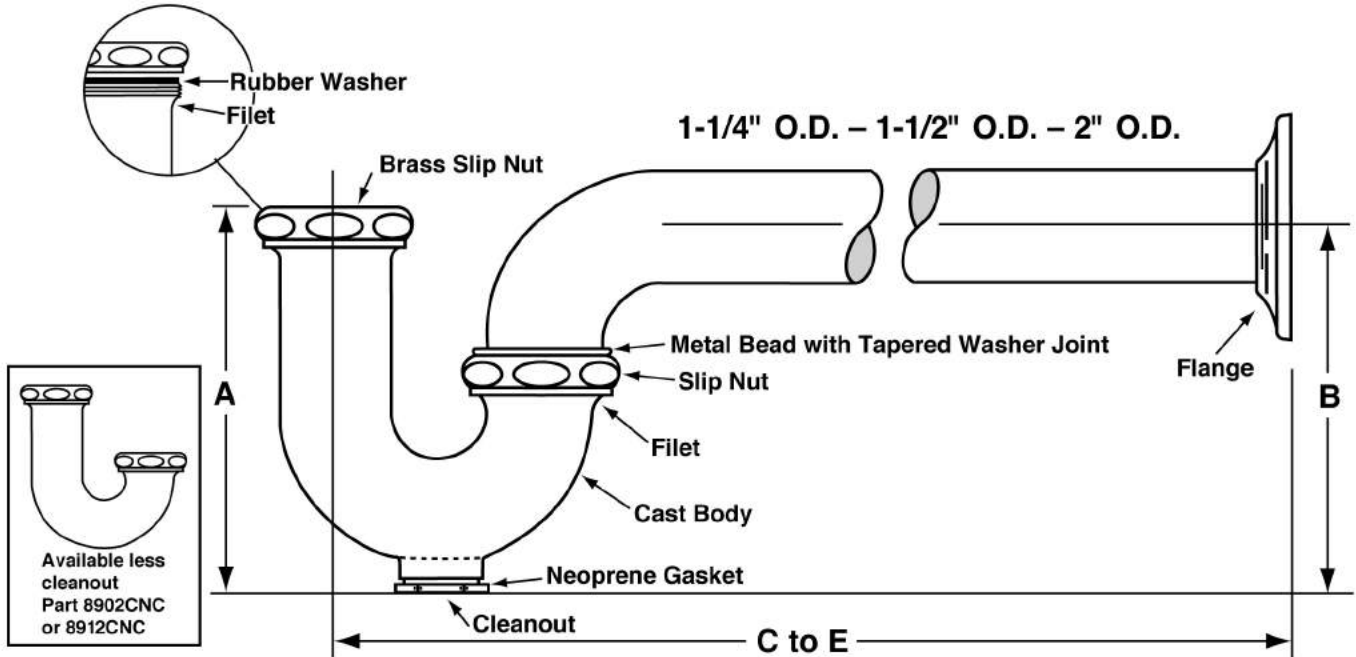

### PROFESSIONAL LINE

#### ROUGHING MEASUREMENTS

NO.	TRAP DIMENSIONS		A	B	C to E
	INLET	OUTLET			
8912CNC	1-1/2"	1-1/2"	4-5/8"	4-1/8"	11-1/2"

**FED SPEC W.W.P. 541  
 CAST BRASS P TRAP  
 MINIMUM SEAL 2"**

See options and accessories section for details on product variations.

ASME A112.18.2/CSA B125-2



## Specifications:

P-Trap shall be chrome plated cast brass body (with, without) cleanout, with 17 gauge seamless tubular wall bend, cast brass slip nuts. Reducing washers shall be used with reducing cast brass nut. With (shallow, deep, bell) (steel, brass) or (forged brass with set screw) flange.

P-Trap shall be McGuire "Classic" Professional Line

Trap shall be certified by CSA or other recognized testing authority. Trap shall bear manufacturer and testing marks.



### WARNING:

This product can expose you to chemicals including lead, which is known to the State of California to cause cancer, and birth defects or other reproductive harm. For more information go to [www.P65Warnings.ca.gov](http://www.P65Warnings.ca.gov).



**McGuire Manufacturing Co., Inc.**

60 Grandview Court  
 Cheshire, Connecticut 06410  
 (203) 699-1801 Fax (203) 699-1813  
 customerservice@mcguiremfg.com mcguiremfg.com

**Part No.**

**8912CNCBECO**

**Cast Body P-Trap With  
 or Without Cleanout**

**PRODUCT SPECIFICATION**

**Job Name:**

**Submittal Number:**

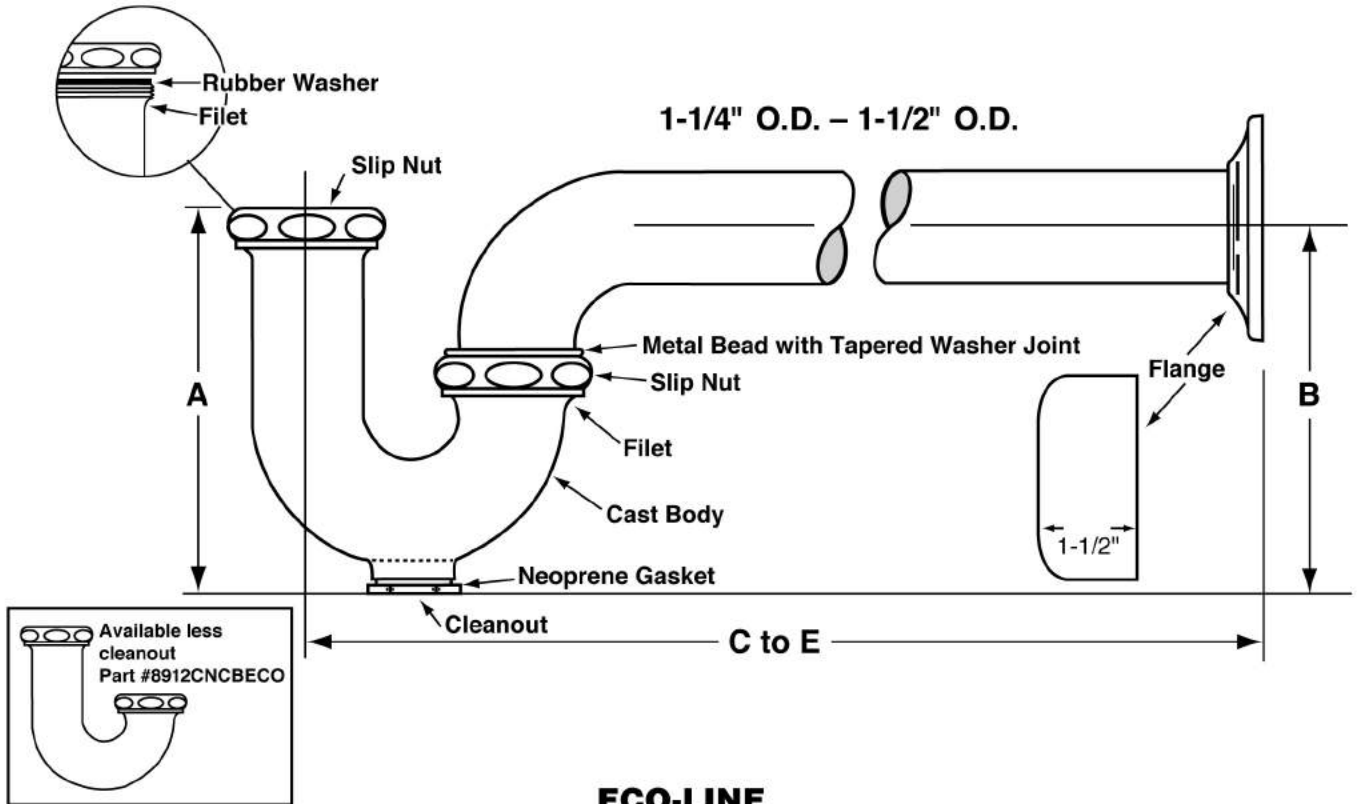

**ECO-LINE**

**ROUGHING MEASUREMENTS**

MODEL NO.	TRAP DIMENSIONS		A	B	C to E	FLANGE	SLIP NUT
	INLET	OUTLET					
8912CNCBECO	1-1/2", 1-1/4"	1-1/2"	4-3/4"	4-1/2"	12"	Box	Brass

**FED SPEC W.W.P. 541  
 CAST BRASS P-TRAP  
 MINIMUM SEAL 2"**



ASME A112.18.2/CSA B125.2

**Specifications:**

Chrome plated P-Trap shall be cast brass body, with or without cleanout, with 17 gauge seamless tubular wall bend and flange.



**WARNING:**

This product can expose you to chemicals including lead, which is known to the State of California to cause cancer, and birth defects or other reproductive harm. For more information go to [www.P65Warnings.ca.gov](http://www.P65Warnings.ca.gov).





**McGuire Manufacturing Co., Inc.**

60 Grandview Court  
 Cheshire, Connecticut 06410  
 (203) 699-1801 Fax (203) 699-1813  
 customerservice@mcguiremfg.com mcguiremfg.com

**Part No.**

**B8872**

**Cast Body P-Trap  
 With or Without Cleanout**

**PRODUCT SPECIFICATION**

**Job Name:**

**Submittal Number:**

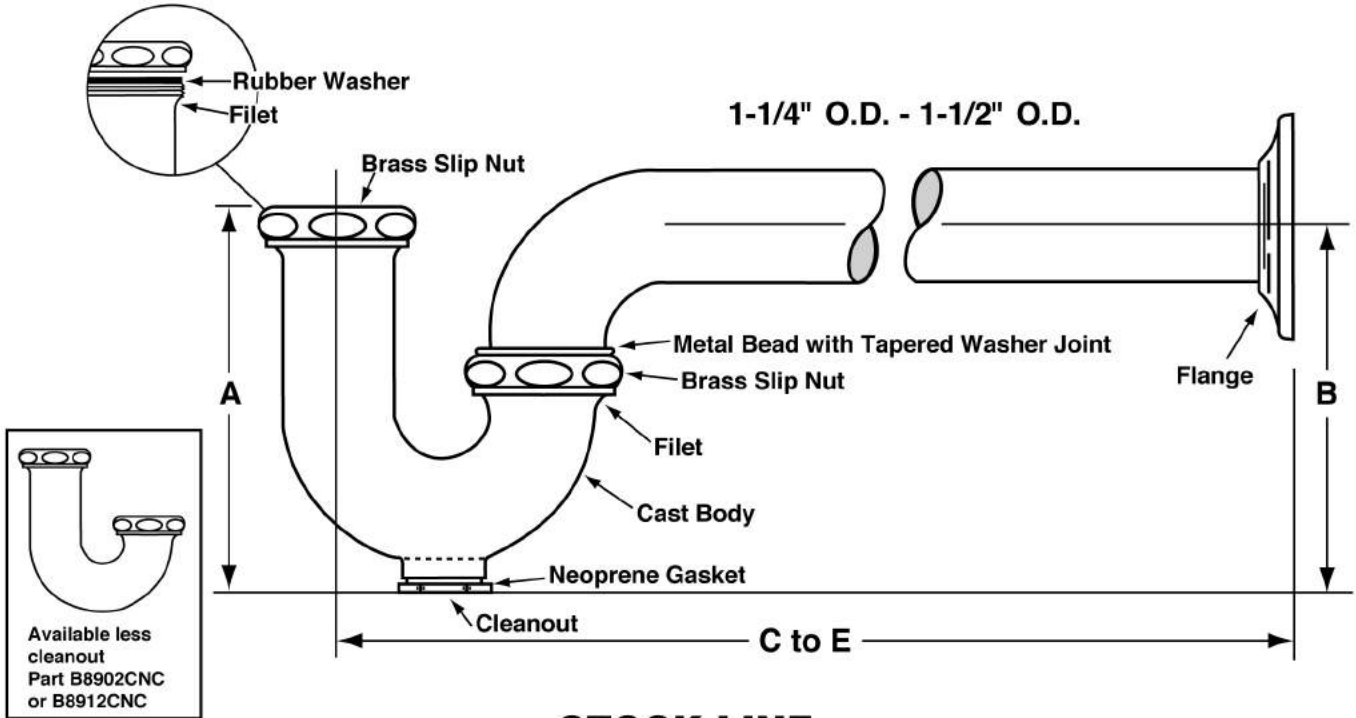

Available less cleanout  
 Part B8902CNC  
 or B8912CNC

**STOCK LINE**

ROUGHING MEASUREMENTS					
NO.	TRAP DIMENSIONS		A	B	C to E
	INLET	OUTLET			
B8872	1-1/4"	1-1/4"	4-1/2"	4-1/2"	10-1/2"

**FED SPEC W.W.P. 541  
 CAST BRASS P TRAP  
 MINIMUM SEAL 2"**

Note: Prefix "C" indicates die cast slip nuts.



See options and accessories section for details on product variations. ASME A112.18.2/CSA B125.2

**Specifications:**

P-Trap shall be chrome plated cast brass body (with, without) cleanout, with 17 gauge seamless tubular wall bend, slip nuts. Reducing washers shall be used with reducing cast brass nut. With (shallow, deep, bell) (steel, brass) or (forged brass with set screw) flange. P-Trap shall bear manufacturer and testing mark.



**WARNING:**

This product can expose you to chemicals including lead, which is known to the State of California to cause cancer, and birth defects or other reproductive harm. For more information go to [www.P65Warnings.ca.gov](http://www.P65Warnings.ca.gov).



**McGuire Manufacturing Co., Inc.**

60 Grandview Court  
 Cheshire, Connecticut 06410  
 (203) 699-1801 Fax (203) 699-1813  
 customerservice@mcguiremfg.com mcguiremfg.com

**Part No.**

**B8872C**

**Cast Body P-Trap  
 With or Without Cleanout**

**PRODUCT SPECIFICATION**

**Job Name:**

**Submittal Number:**

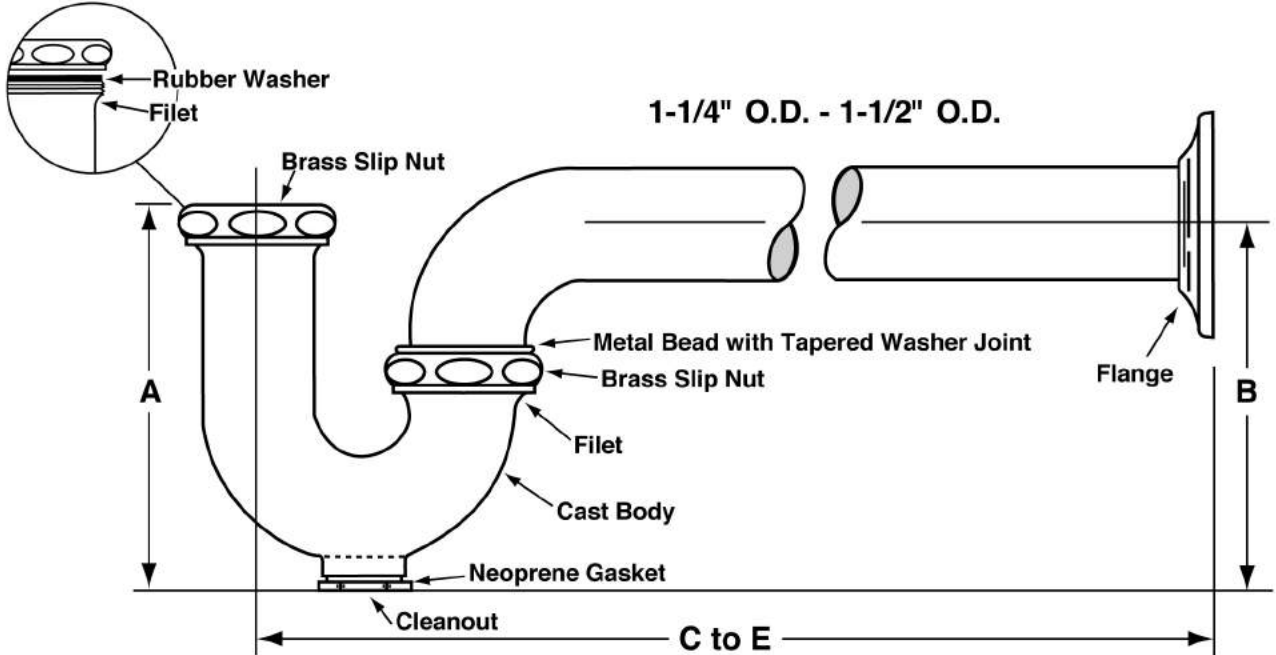

**STOCK LINE**

ROUGHING MEASUREMENTS					
NO.	TRAP DIMENSIONS		A	B	C to E
	INLET	OUTLET			
B8872C	1-1/4"	1-1/4"	4-1/2"	4-1/2"	10-1/2"

**FED SPEC W.W.P. 541  
 CAST BRASS P TRAP  
 MINIMUM SEAL 2"**



See options and accessories section for details on product variations. ASME A112.18.2/CSA B125.2

**Specifications:**

P-Trap shall be chrome plated cast brass body (with, without) cleanout, with 17 gauge seamless tubular wall bend, slip nuts. Reducing washers shall be used with reducing cast brass nut. With (shallow, deep, bell) (steel, brass) or (forged brass with set screw) flange. P-Trap shall bear manufacturer and testing mark.



**WARNING:**

This product can expose you to chemicals including lead, which is known to the State of California to cause cancer, and birth defects or other reproductive harm. For more information go to [www.P65Warnings.ca.gov](http://www.P65Warnings.ca.gov).



**McGuire Manufacturing Co., Inc.**

60 Grandview Court  
 Cheshire, Connecticut 06410  
 (203) 699-1801 Fax (203) 699-1813  
 customerservice@mcguiremfg.com mcguiremfg.com

**Part No.**

**B8902**

**Cast Body P-Trap  
 With or Without Cleanout**

**PRODUCT SPECIFICATION**

**Job Name:**

**Submittal Number:**

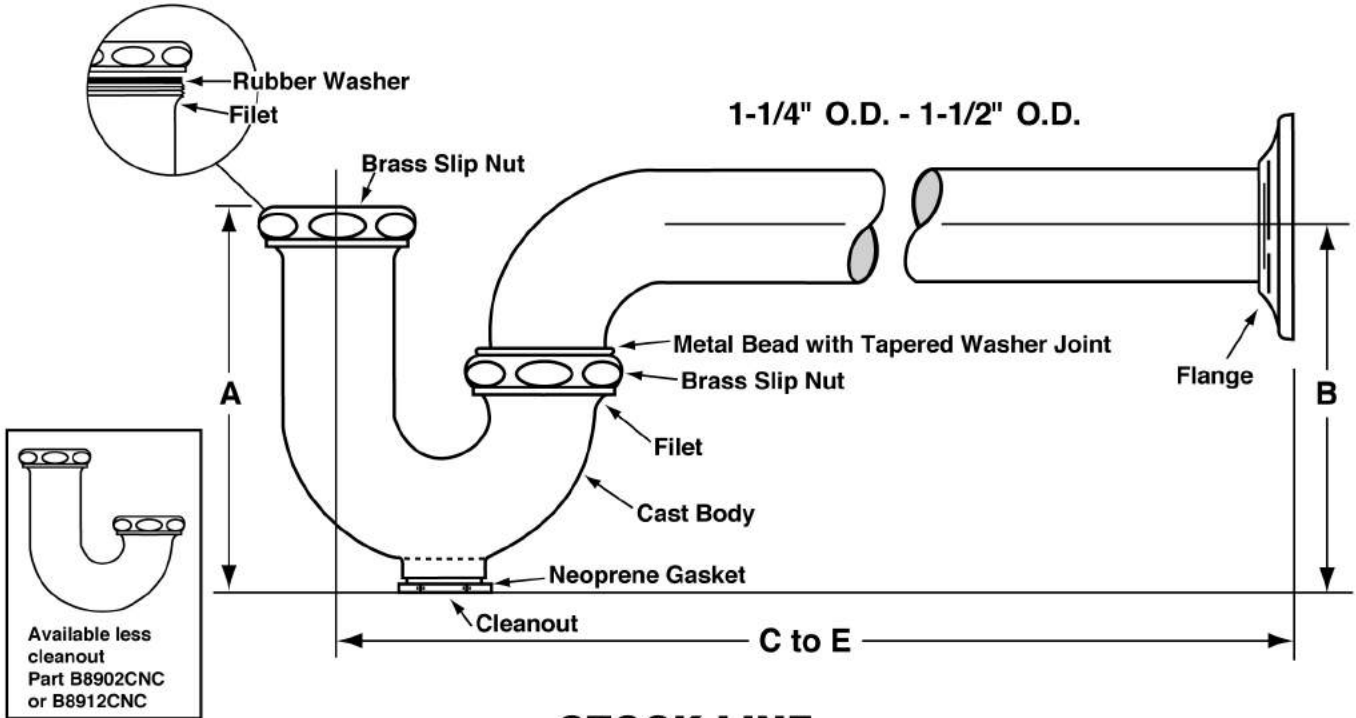

**STOCK LINE**

ROUGHING MEASUREMENTS					
NO.	TRAP DIMENSIONS		A	B	C to E
	INLET	OUTLET			
B8902	1-1/4"	1-1/2"	5"	5-1/2"	10-1/2"

**FED SPEC W.W.P. 541  
 CAST BRASS P TRAP  
 MINIMUM SEAL 2"**

Note: Prefix "C" indicates die cast slip nuts.



See options and accessories section for details on product variations. ASME A112.18.2/CSA B125.2

**Specifications:**

P-Trap shall be chrome plated cast brass body (with, without) cleanout, with 17 gauge seamless tubular wall bend, slip nuts. Reducing washers shall be used with reducing cast brass nut. With (shallow, deep, bell) (steel, brass) or (forged brass with set screw) flange. P-Trap shall bear manufacturer and testing mark.



**WARNING:**

This product can expose you to chemicals including lead, which is known to the State of California to cause cancer, and birth defects or other reproductive harm. For more information go to [www.P65Warnings.ca.gov](http://www.P65Warnings.ca.gov).



**McGuire Manufacturing Co., Inc.**

60 Grandview Court  
 Cheshire, Connecticut 06410  
 (203) 699-1801 Fax (203) 699-1813  
 customerservice@mcguiremfg.com mcguiremfg.com

**Part No.**

**B8902C**

**Cast Body P-Trap  
 With or Without Cleanout**

**PRODUCT SPECIFICATION**

**Job Name:**

**Submittal Number:**

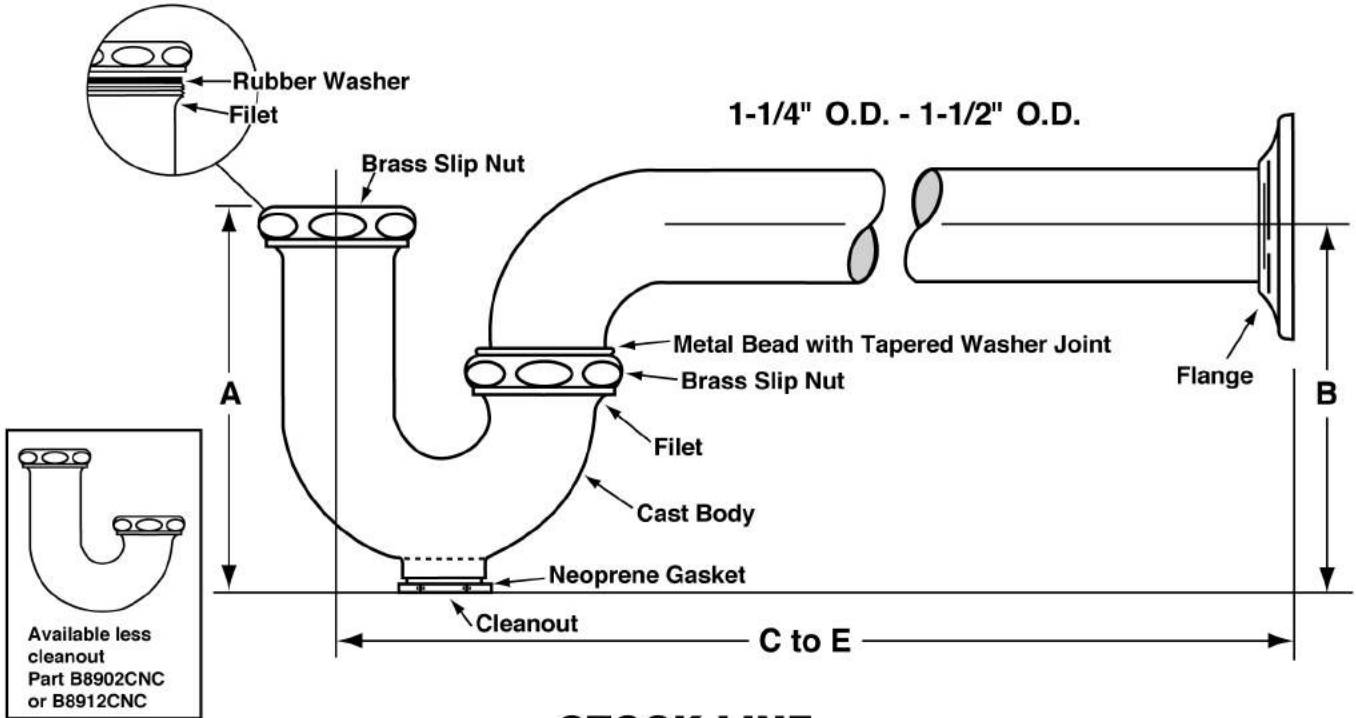

**STOCK LINE**

ROUGHING MEASUREMENTS					
NO.	TRAP DIMENSIONS		A	B	C to E
	INLET	OUTLET			
B8902C	1-1/4"	1-1/2"	5"	5-1/2"	10-1/2"

**FED SPEC W.W.P. 541  
 CAST BRASS P TRAP  
 MINIMUM SEAL 2"**



See options and accessories section for details on product variations. ASME A112.18.2/CSA B125.2

**Specifications:**

P-Trap shall be chrome plated cast brass body (with, without) cleanout, with 17 gauge seamless tubular wall bend, slip nuts. Reducing washers shall be used with reducing cast brass nut. With (shallow, deep, bell) (steel, brass) or (forged brass with set screw) flange. P-Trap shall bear manufacturer and testing mark.



**WARNING:**

This product can expose you to chemicals including lead, which is known to the State of California to cause cancer, and birth defects or other reproductive harm. For more information go to [www.P65Warnings.ca.gov](http://www.P65Warnings.ca.gov).





# McGuire Manufacturing Co., Inc.

60 Grandview Court  
 Cheshire, Connecticut 06410  
 (203) 699-1801 Fax (203) 699-1813  
 customerservice@mcguiremfg.com mcguiremfg.com

**Part No.**

**B8902CNC**

**Cast Body P-Trap  
 With or Without Cleanout**

## PRODUCT SPECIFICATION

**Job Name:**

**Submittal Number:**

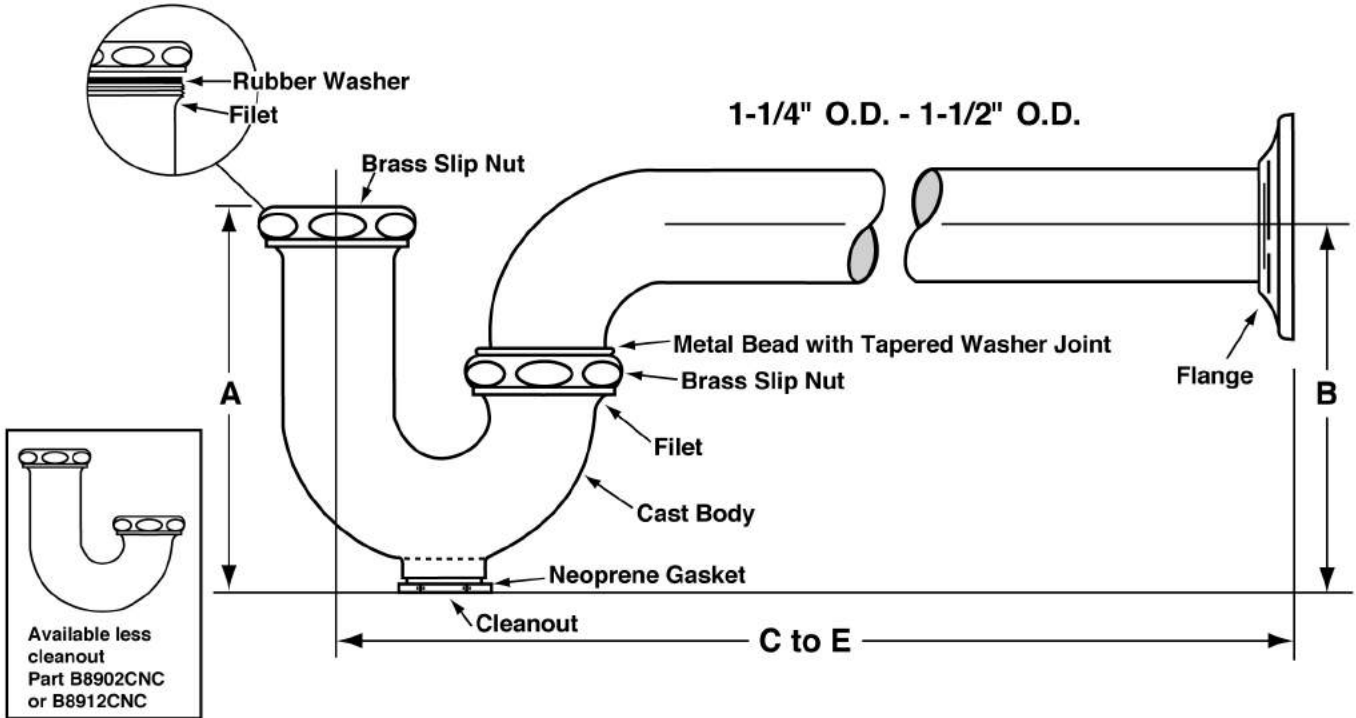

ROUGHING MEASUREMENTS					
NO.	TRAP DIMENSIONS		A	B	C to E
	INLET	OUTLET			
B8902CNC	1-1/4"	1-1/2"	4-3/4"	4-1/2"	10-1/2"

**FED SPEC W.W.P. 541  
 CAST BRASS P TRAP  
 MINIMUM SEAL 2"**



See options and accessories section for details on product variations. ASME A112.18.2/CSA B125.2

## Specifications:

P-Trap shall be chrome plated cast brass body (with, without) cleanout, with 17 gauge seamless tubular wall bend, slip nuts. Reducing washers shall be used with reducing cast brass nut. With (shallow, deep, bell) (steel, brass) or (forged brass with set screw) flange. P-Trap shall bear manufacturer and testing mark.



### WARNING:

This product can expose you to chemicals including lead, which is known to the State of California to cause cancer, and birth defects or other reproductive harm. For more information go to [www.P65Warnings.ca.gov](http://www.P65Warnings.ca.gov).



**McGuire Manufacturing Co., Inc.**

60 Grandview Court  
 Cheshire, Connecticut 06410  
 (203) 699-1801 Fax (203) 699-1813  
 customerservice@mcguiremfg.com mcguiremfg.com

**Part No.**

**B8912**

**Cast Body P-Trap  
 With or Without Cleanout**

**PRODUCT SPECIFICATION**

**Job Name:**

**Submittal Number:**

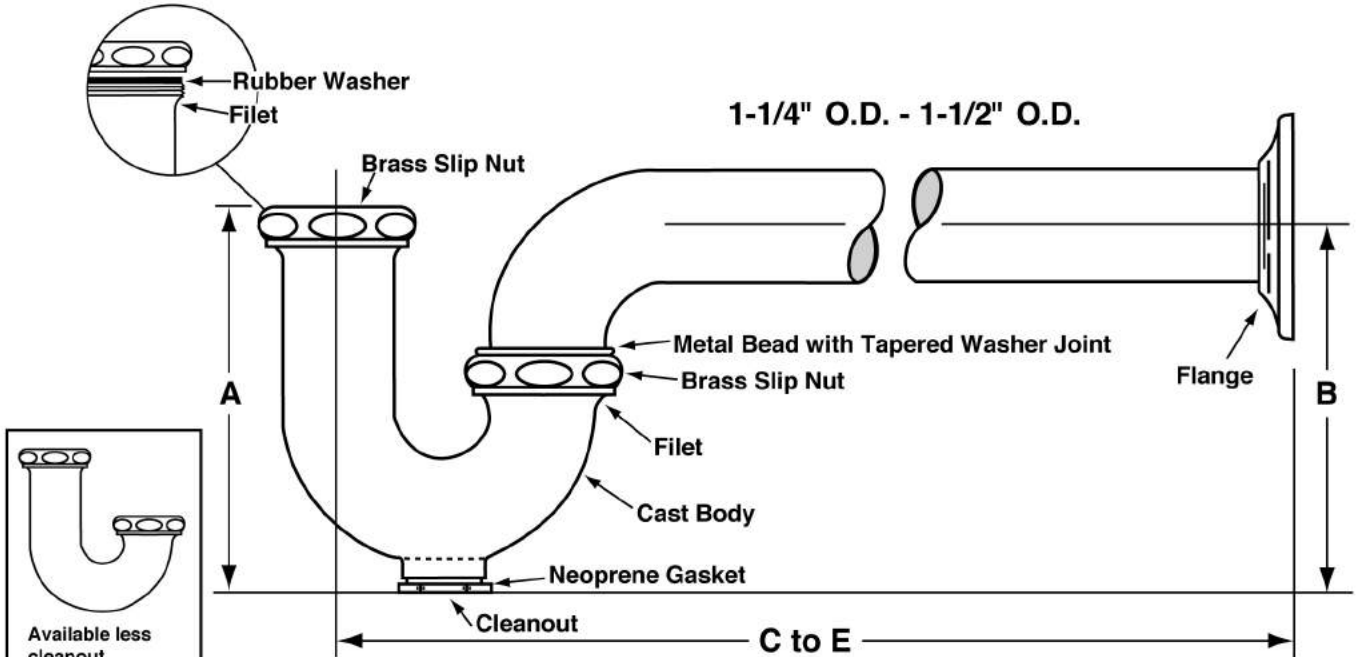

**STOCK LINE**

ROUGHING MEASUREMENTS					
NO.	TRAP DIMENSIONS		A	B	C to E
	INLET	OUTLET			
B8912	1-1/2"	1-1/2"	5"	4-1/2"	10-1/2"

**FED SPEC W.W.P. 541  
 CAST BRASS P TRAP  
 MINIMUM SEAL 2"**



See options and accessories section for details on product variations. ASME A112.18.2/CSA B125.2

**Specifications:**

P-Trap shall be chrome plated cast brass body (with, without) cleanout, with 17 gauge seamless tubular wall bend, slip nuts. Reducing washers shall be used with reducing cast brass nut. With (shallow, deep, bell) (steel, brass) or (forged brass with set screw) flange. P-Trap shall bear manufacturer and testing mark.



**WARNING:**

This product can expose you to chemicals including lead, which is known to the State of California to cause cancer, and birth defects or other reproductive harm. For more information go to [www.P65Warnings.ca.gov](http://www.P65Warnings.ca.gov).



**McGuire Manufacturing Co., Inc.**

60 Grandview Court  
 Cheshire, Connecticut 06410  
 (203) 699-1801 Fax (203) 699-1813  
 customerservice@mcguiremfg.com mcguiremfg.com

**Part No.**

**B8912C**

**Cast Body P-Trap  
 With or Without Cleanout**

**PRODUCT SPECIFICATION**

**Job Name:**

**Submittal Number:**

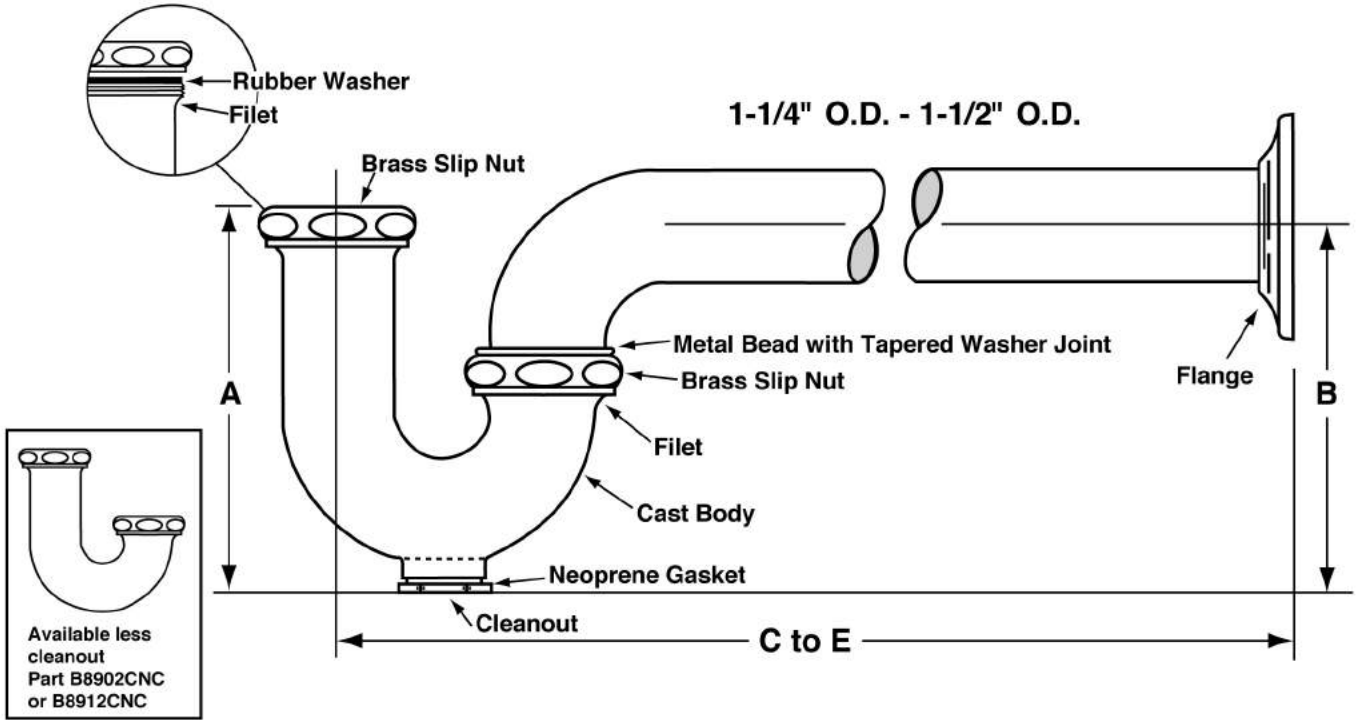

ROUGHING MEASUREMENTS					
NO.	TRAP DIMENSIONS		A	B	C to E
	INLET	OUTLET			
B8912C	1-1/2"	1-1/2"	5"	4-1/2"	10-1/2"

**FED SPEC W.W.P. 541  
 CAST BRASS P TRAP  
 MINIMUM SEAL 2"**



See options and accessories section for details on product variations. ASME A112.18.2/CSA B125.2

**Specifications:**

P-Trap shall be chrome plated cast brass body (with, without) cleanout, with 17 gauge seamless tubular wall bend, slip nuts. Reducing washers shall be used with reducing cast brass nut. With (shallow, deep, bell) (steel, brass) or (forged brass with set screw) flange. P-Trap shall bear manufacturer and testing mark.



**WARNING:**

This product can expose you to chemicals including lead, which is known to the State of California to cause cancer, and birth defects or other reproductive harm. For more information go to [www.P65Warnings.ca.gov](http://www.P65Warnings.ca.gov).



# McGuire Manufacturing Co., Inc.

60 Grandview Court  
 Cheshire, Connecticut 06410  
 (203) 699-1801 Fax (203) 699-1813  
 customerservice@mcguiremfg.com mcguiremfg.com

**Part No.**

**B8912CNC**

**Cast Body P-Trap  
 With or Without Cleanout**

## PRODUCT SPECIFICATION

**Job Name:**

**Submittal Number:**

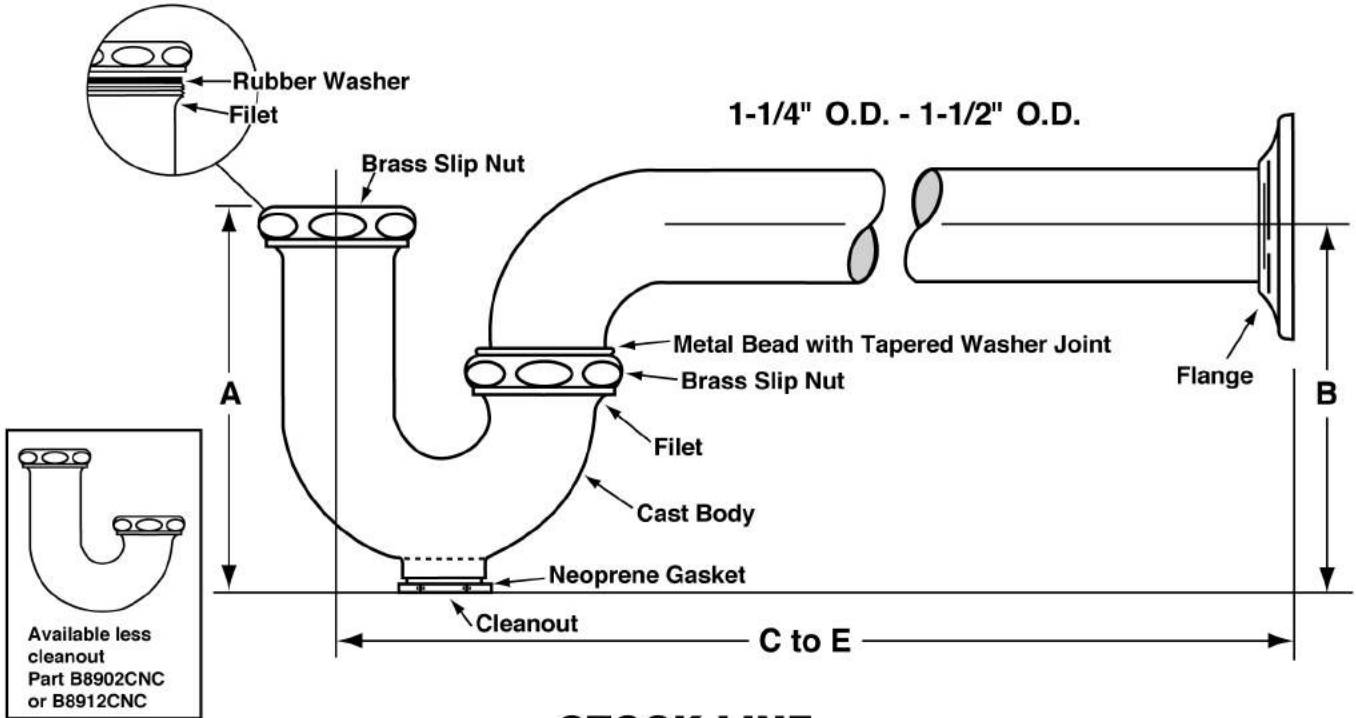

### STOCK LINE

ROUGHING MEASUREMENTS					
NO.	TRAP DIMENSIONS		A	B	C to E
	INLET	OUTLET			
B8912CNC	1-1/2"	1-1/2"	4-5/8"	4-1/8"	10-1/2"

**FED SPEC W.W.P. 541  
 CAST BRASS P TRAP  
 MINIMUM SEAL 2"**

Note: Prefix "C" indicates die cast slip nuts.



See options and accessories section for details on product variations. ASME A112.18.2/CSA B125.2

### Specifications:

P-Trap shall be chrome plated cast brass body (with, without) cleanout, with 17 gauge seamless tubular wall bend, slip nuts. Reducing washers shall be used with reducing cast brass nut. With (shallow, deep, bell) (steel, brass) or (forged brass with set screw) flange. P-Trap shall bear manufacturer and testing mark.



**WARNING:**

This product can expose you to chemicals including lead, which is known to the State of California to cause cancer, and birth defects or other reproductive harm. For more information go to [www.P65Warnings.ca.gov](http://www.P65Warnings.ca.gov).





# McGuire Manufacturing Co., Inc.

60 Grandview Court  
 Cheshire, Connecticut 06410  
 (203) 699-1801 Fax (203) 699-1813  
 customerservice@mcguiremfg.com mcguiremfg.com

**Part No.**

**C8872**

**Cast Body P-Trap  
 With or Without Cleanout**

## PRODUCT SPECIFICATION

**Job Name:**

**Submittal Number:**

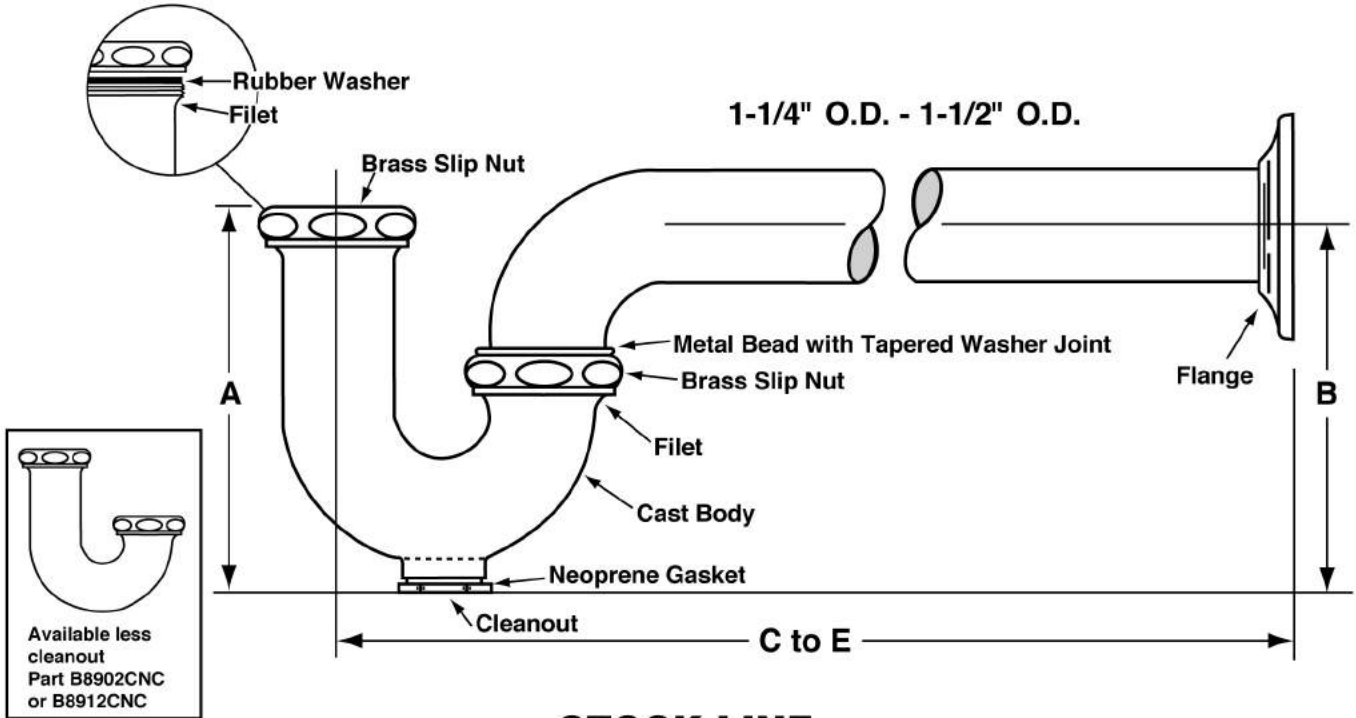

### STOCK LINE

ROUGHING MEASUREMENTS					
NO.	TRAP DIMENSIONS		A	B	C to E
	INLET	OUTLET			
C8872	1-1/4"	1-1/4"	4-1/2"	4-1/4"	10"

**FED SPEC W.W.P. 541  
 CAST BRASS P TRAP  
 MINIMUM SEAL 2"**

**Note: Prefix "C" indicates die cast slip nuts.**



See options and accessories section for details on product variations. ASME A112.18.2/CSA B125.2

### Specifications:

P-Trap shall be chrome plated cast brass body (with, without) cleanout, with 17 gauge seamless tubular wall bend, slip nuts. Reducing washers shall be used with reducing cast brass nut. With (shallow, deep, bell) (steel, brass) or (forged brass with set screw) flange. P-Trap shall bear manufacturer and testing mark.



**WARNING:**

This product can expose you to chemicals including lead, which is known to the State of California to cause cancer, and birth defects or other reproductive harm. For more information go to [www.P65Warnings.ca.gov](http://www.P65Warnings.ca.gov).



**McGuire Manufacturing Co., Inc.**

60 Grandview Court  
 Cheshire, Connecticut 06410  
 (203) 699-1801 Fax (203) 699-1813  
 customerservice@mcguiremfg.com mcguiremfg.com

**Part No.**

**C8872CECO**

**Cast Body P-Trap With  
 or Without Cleanout**

**PRODUCT SPECIFICATION**

**Job Name:**

**Submittal Number:**

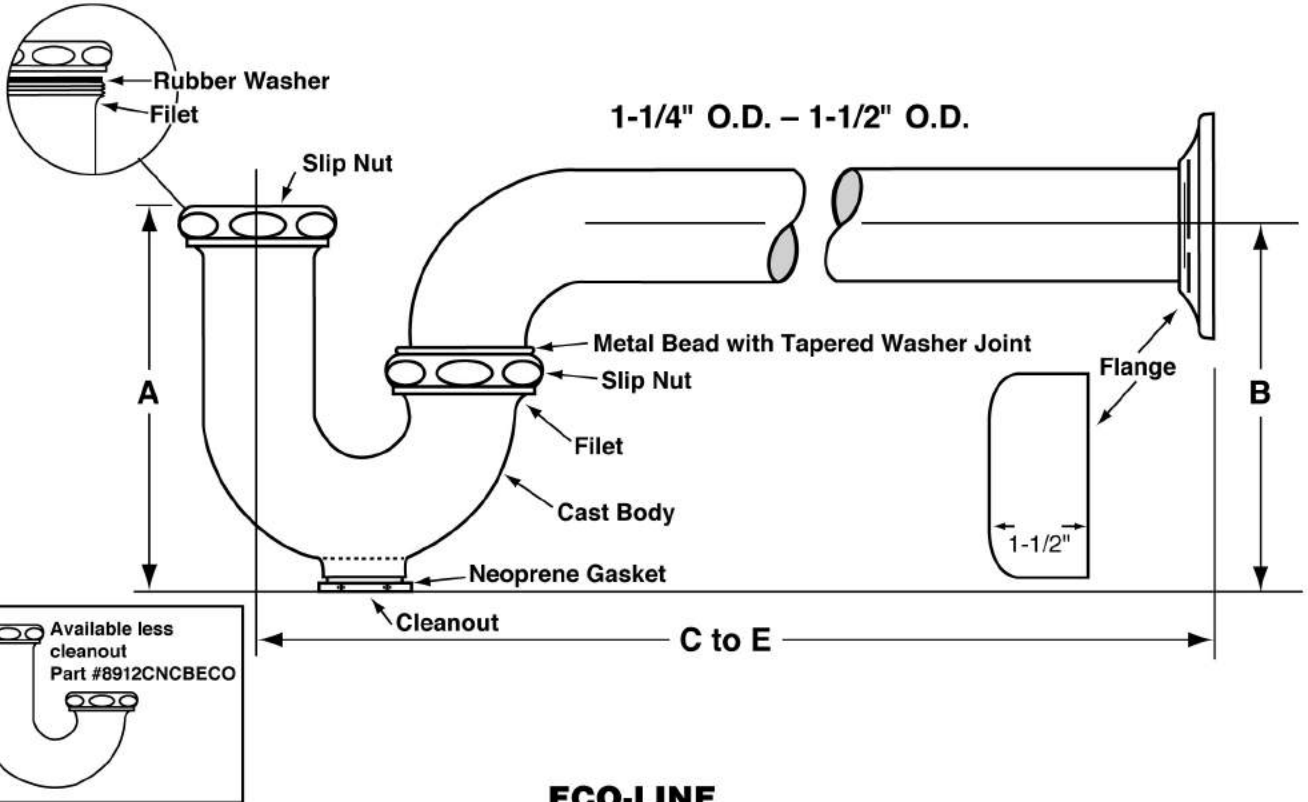

**ECO-LINE**

**ROUGHING MEASUREMENTS**

MODEL NO.	TRAP DIMENSIONS		A	B	C to E	FLANGE	SLIP NUT
	INLET	OUTLET					
C8872CECO	1-1/4"	1-1/4"	4-1/2"	4-1/2"	10"	Shallow	Zinc

**FED SPEC W.W.P. 541  
 CAST BRASS P-TRAP  
 MINIMUM SEAL 2"**



ASME A112.18.2/CSA B125.2

**Specifications:**

Chrome plated P-Trap shall be cast brass body, with or without cleanout, with 17 gauge seamless tubular wall bend and flange.



**WARNING:**

This product can expose you to chemicals including lead, which is known to the State of California to cause cancer, and birth defects or other reproductive harm. For more information go to [www.P65Warnings.ca.gov](http://www.P65Warnings.ca.gov).



**McGuire Manufacturing Co., Inc.**

60 Grandview Court  
 Cheshire, Connecticut 06410  
 (203) 699-1801 Fax (203) 699-1813  
 customerservice@mcguiremfg.com mcguiremfg.com

**PRODUCT SPECIFICATION**

**Part No.**

**C8902**

**Cast Body P-Trap  
 With or Without Cleanout**

**Job Name:**

**Submittal Number:**

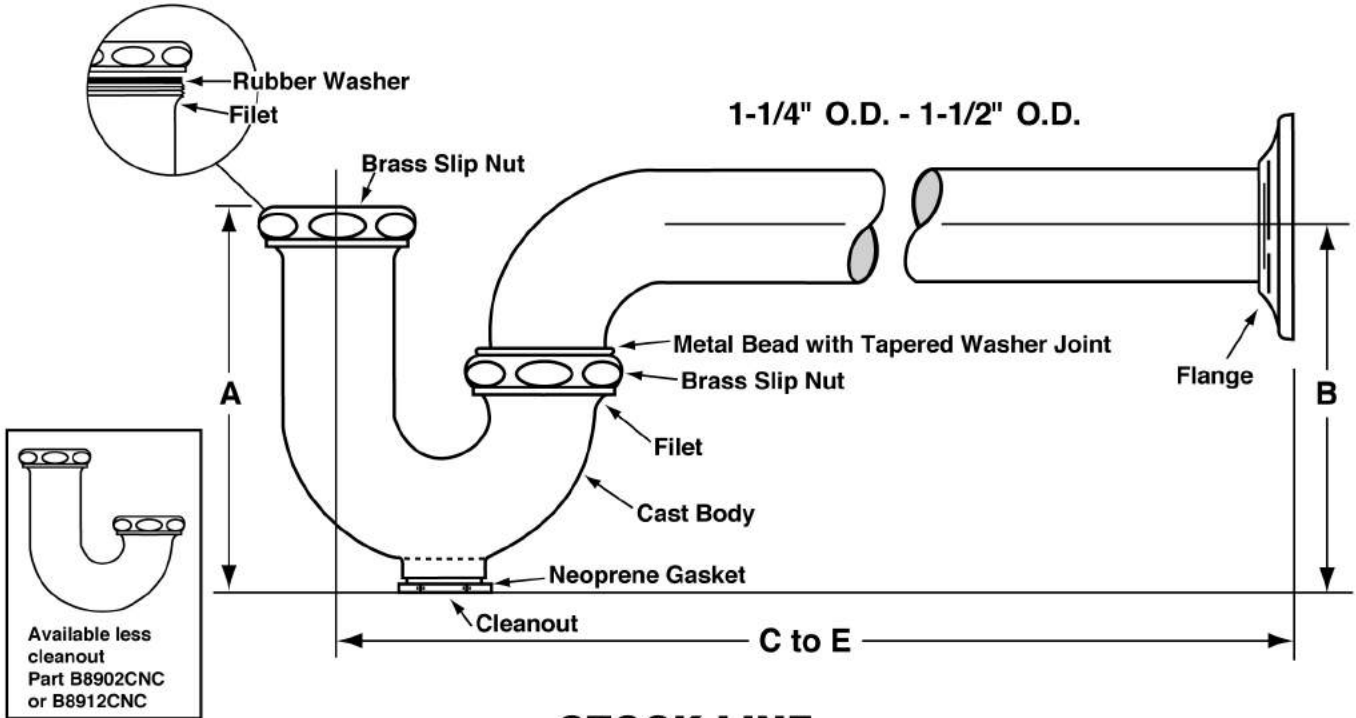

**STOCK LINE**

ROUGHING MEASUREMENTS					
NO.	TRAP DIMENSIONS		A	B	C to E
	INLET	OUTLET			
C8902	1-1/4"	1-1/2"	5"	5-1/2"	10-1/2"

**FED SPEC W.W.P. 541  
 CAST BRASS P TRAP  
 MINIMUM SEAL 2"**

**Note: Prefix "C" indicates die cast slip nuts.**



See options and accessories section for details on product variations. ASME A112.18.2/CSA B125.2

**Specifications:**

P-Trap shall be chrome plated cast brass body (with, without) cleanout, with 17 gauge seamless tubular wall bend, slip nuts. Reducing washers shall be used with reducing cast brass nut. With (shallow, deep, bell) (steel, brass) or (forged brass with set screw) flange. P-Trap shall bear manufacturer and testing mark.



**WARNING:**

This product can expose you to chemicals including lead, which is known to the State of California to cause cancer, and birth defects or other reproductive harm. For more information go to [www.P65Warnings.ca.gov](http://www.P65Warnings.ca.gov).



**McGuire Manufacturing Co., Inc.**

60 Grandview Court  
 Cheshire, Connecticut 06410  
 (203) 699-1801 Fax (203) 699-1813  
 customerservice@mcguiremfg.com mcguiremfg.com

**Part No.**

**C8912**

**Cast Body P-Trap  
 With or Without Cleanout**

**PRODUCT SPECIFICATION**

**Job Name:**

**Submittal Number:**

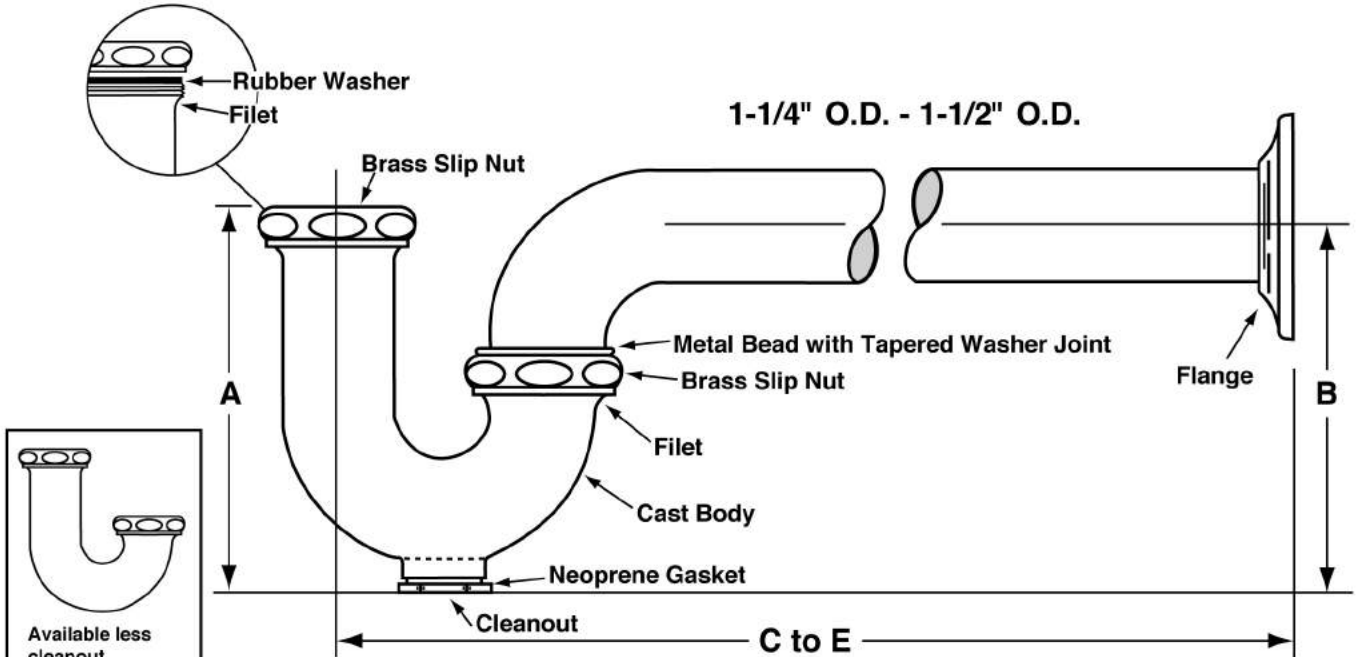

Available less cleanout  
 Part B8902CNC  
 or B8912CNC

**STOCK LINE**

ROUGHING MEASUREMENTS					
NO.	TRAP DIMENSIONS		A	B	C to E
	INLET	OUTLET			
C8912	1-1/2"	1-1/2"	5"	4-1/2"	10-1/2"

**FED SPEC W.W.P. 541  
 CAST BRASS P TRAP  
 MINIMUM SEAL 2"**

Note: Prefix "C" indicates die cast slip nuts.



See options and accessories section for details on product variations. ASME A112.18.2/CSA B125.2

**Specifications:**

P-Trap shall be chrome plated cast brass body (with, without) cleanout, with 17 gauge seamless tubular wall bend, slip nuts. Reducing washers shall be used with reducing cast brass nut. With (shallow, deep, bell) (steel, brass) or (forged brass with set screw) flange. P-Trap shall bear manufacturer and testing mark.



**WARNING:**

This product can expose you to chemicals including lead, which is known to the State of California to cause cancer, and birth defects or other reproductive harm. For more information go to [www.P65Warnings.ca.gov](http://www.P65Warnings.ca.gov).



**McGuire Manufacturing Co., Inc.**

60 Grandview Court  
 Cheshire, Connecticut 06410  
 (203) 699-1801 Fax (203) 699-1813  
 customerservice@mcguiremfg.com mcguiremfg.com

**Part No.**

**C8912CECO**

**Cast Body P-Trap With  
 or Without Cleanout**

**PRODUCT SPECIFICATION**

**Job Name:**

**Submittal Number:**

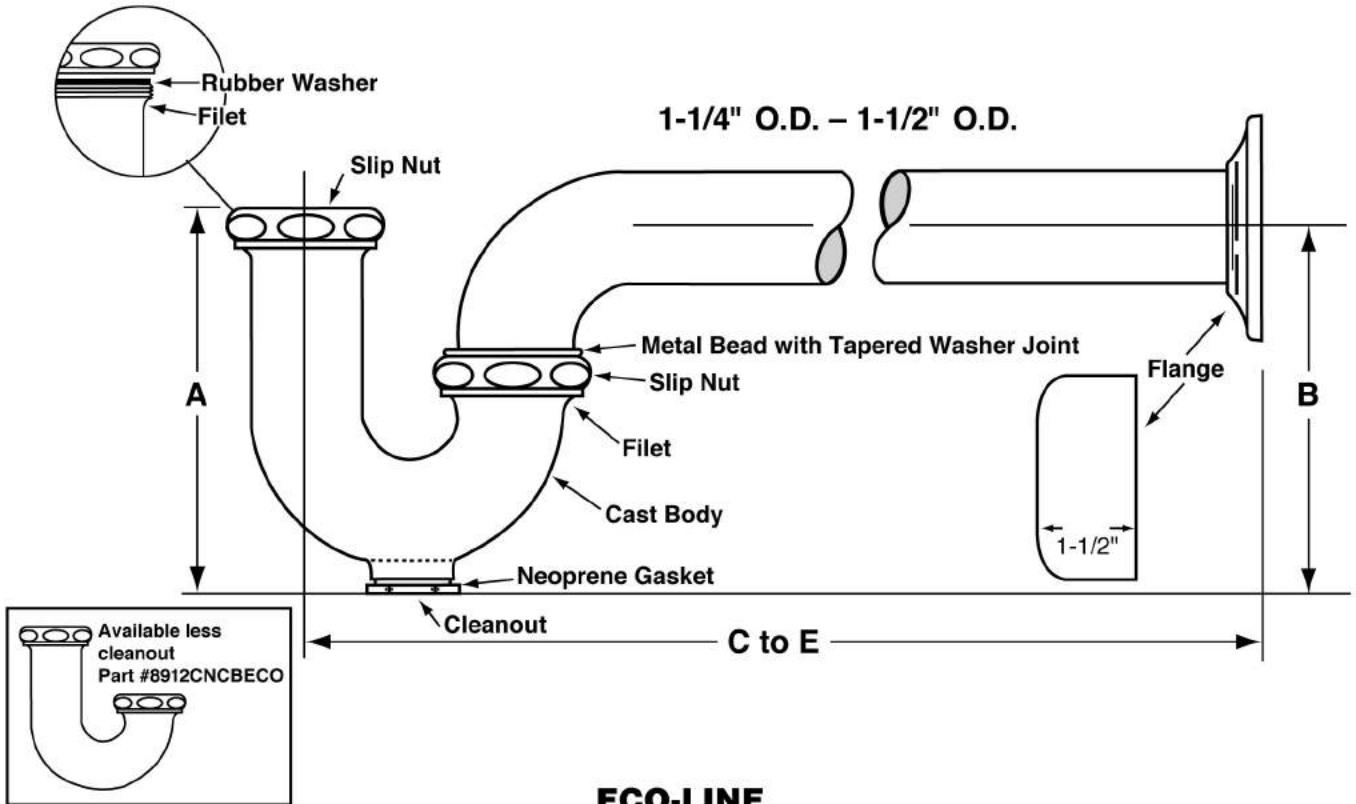

**ECO-LINE**

**ROUGHING MEASUREMENTS**

MODEL NO.	TRAP DIMENSIONS		A	B	C to E	FLANGE	SLIP NUT
	INLET	OUTLET					
C8912CECO	1-1/2", 1-1/4"	1-1/2"	5"	5"	10-1/2"	Shallow	Zinc

**FED SPEC W.W.P. 541  
 CAST BRASS P-TRAP  
 MINIMUM SEAL 2"**



ASME A112.18.2/CSA B125.2

**Specifications:**

Chrome plated P-Trap shall be cast brass body, with or without cleanout, with 17 gauge seamless tubular wall bend and flange.



**WARNING:**

This product can expose you to chemicals including lead, which is known to the State of California to cause cancer, and birth defects or other reproductive harm. For more information go to [www.P65Warnings.ca.gov](http://www.P65Warnings.ca.gov).





# McGuire Manufacturing Co., Inc.

60 Grandview Court  
 Cheshire, Connecticut 06410  
 (203) 699-1801 Fax (203) 699-1813  
 customerservice@mcguiremfg.com mcguiremfg.com

## PRODUCT SPECIFICATION

Part No.

**MCT125 Series**

**Lite Commercial 17 GA  
 Tubular P-Trap**

**Job Name:**

**Submittal Number:**

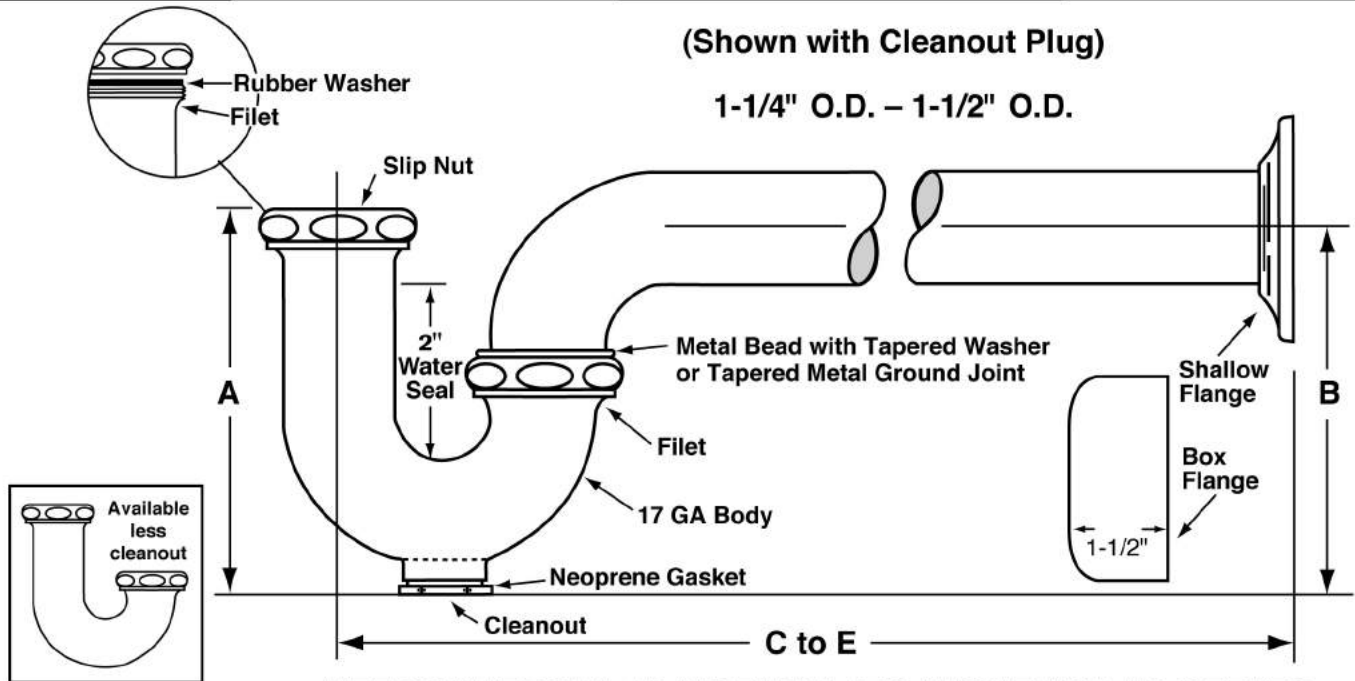

### LITE COMMERCIAL ADJUSTABLE 17 GAUGE TUBULAR P-TRAPS

#### Roughing Measurements

Model No.	INLET	OUTLET	A	B	C to E	Flange	Slip Nut
MCT125085	1-1/4"	1-1/4"	5"	4-1/2"	11-1/2"	Shallow	Brass
MCT125085B	1-1/4"	1-1/4"	5-1/4"	4-1/2"	11-1/2"	Box	Brass
MCT125085NC	1-1/4"	1-1/4"	5"	5"	11-1/2"	Shallow	Brass
MCT125085NCB	1-1/4"	1-1/4"	5"	4-5/8"	11-1/2"	Box	Brass
MCT125075ZN	1-1/4"	1-1/4"	5-1/4"	4-3/4"	10-1/2"	Shallow	Zinc
MCT125075NCZN	1-1/4"	1-1/4"	5"	4-1/2"	10-1/2"	Shallow	Zinc

#### Suffix Designations

NC = No Cleanout Plug

GJ = Ground Joint Wall Bend



ASME A112.18.2/CSA B125.2

### Specifications:

P-Trap shall be 17 gauge seamless chrome plated tubular brass with wall bend and flange.

#### WARNING:

This product can expose you to chemicals including lead, which is known to the State of California to cause cancer, and birth defects or other reproductive harm. For more information go to [www.P65Warnings.ca.gov](http://www.P65Warnings.ca.gov).



# McGuire Manufacturing Co., Inc.

60 Grandview Court  
 Cheshire, Connecticut 06410  
 (203) 699-1801 Fax (203) 699-1813  
 customerservice@mcguiremfg.com mcguiremfg.com

## PRODUCT SPECIFICATION

Part No.

**MCT150 Series**

**Lite Commercial 17 GA  
 Tubular P-Trap**

**Job Name:**

**Submittal Number:**

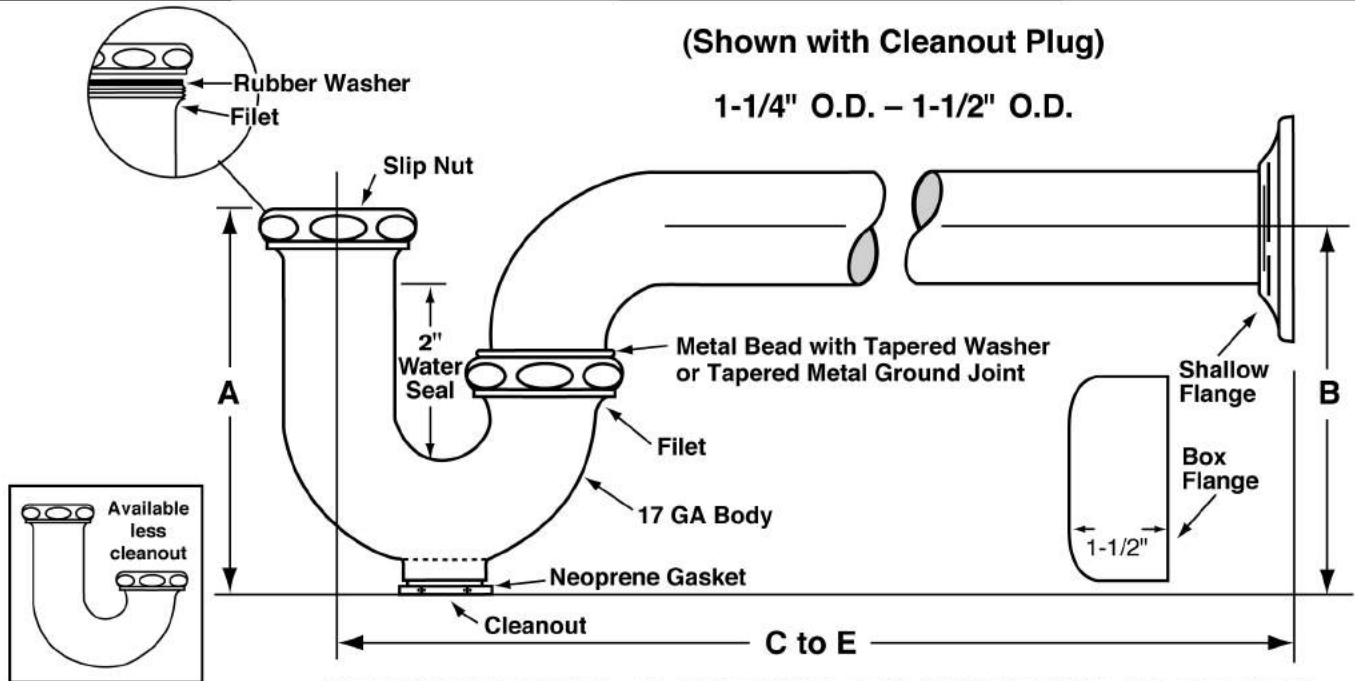

### LITE COMMERCIAL ADJUSTABLE 17 GAUGE TUBULAR P-TRAPS

#### Roughing Measurements

Model No.	INLET	OUTLET	A	B	C to E	Flange	Slip Nut
MCT150090B	1-1/2", 1-1/4"	1-1/2"	5-1/4"	5"	12"	Box	Brass
MCT150075ZN	1-1/2", 1-1/4"	1-1/2"	5-1/2"	5"	10-1/2"	Shallow	Zinc
MCT150075NCZN	1-1/2", 1-1/4"	1-1/2"	5"	4-3/4"	11"	Shallow	Zinc
MCT150090NCB	1-1/2", 1-1/4"	1-1/2"	5-1/4"	4-1/2"	12-1/4"	Box	Brass
MCT150090NCGJB	1-1/2", 1-1/4"	1-1/2"	5-1/4"	4-3/4"	12-1/4"	Box	Brass
MCT150090NCGJ	1-1/2", 1-1/4"	1-1/2"	5-1/4"	5"	12-1/4"	Shallow	Brass
MCT150150B	1-1/2", 1-1/4"	1-1/2"	5-1/4"	5"	18"	Box	Brass

#### Suffix Designations

NC = No Cleanout Plug

GJ = Ground Joint Wall Bend



ASME A112.18.2/CSA B125.2

### Specifications:

P-Trap shall be 17 gauge seamless chrome plated tubular brass with wall bend and flange.

#### WARNING:

This product can expose you to chemicals including lead, which is known to the State of California to cause cancer, and birth defects or other reproductive harm. For more information go to [www.P65Warnings.ca.gov](http://www.P65Warnings.ca.gov).



# McGuire Manufacturing Co., Inc.

60 Grandview Court  
 Cheshire, Connecticut 06410  
 (203) 699-1801 Fax (203) 699-1813  
 customerservice@mcguiremfg.com mcguiremfg.com

## PRODUCT SPECIFICATION

### Part No.

**MCT150UTL17B**

**17GA P-Trap  
 Adjustable Milwaukee  
 Style, N.Y. Utility Style**

**Job Name:**

**Submittal Number:**

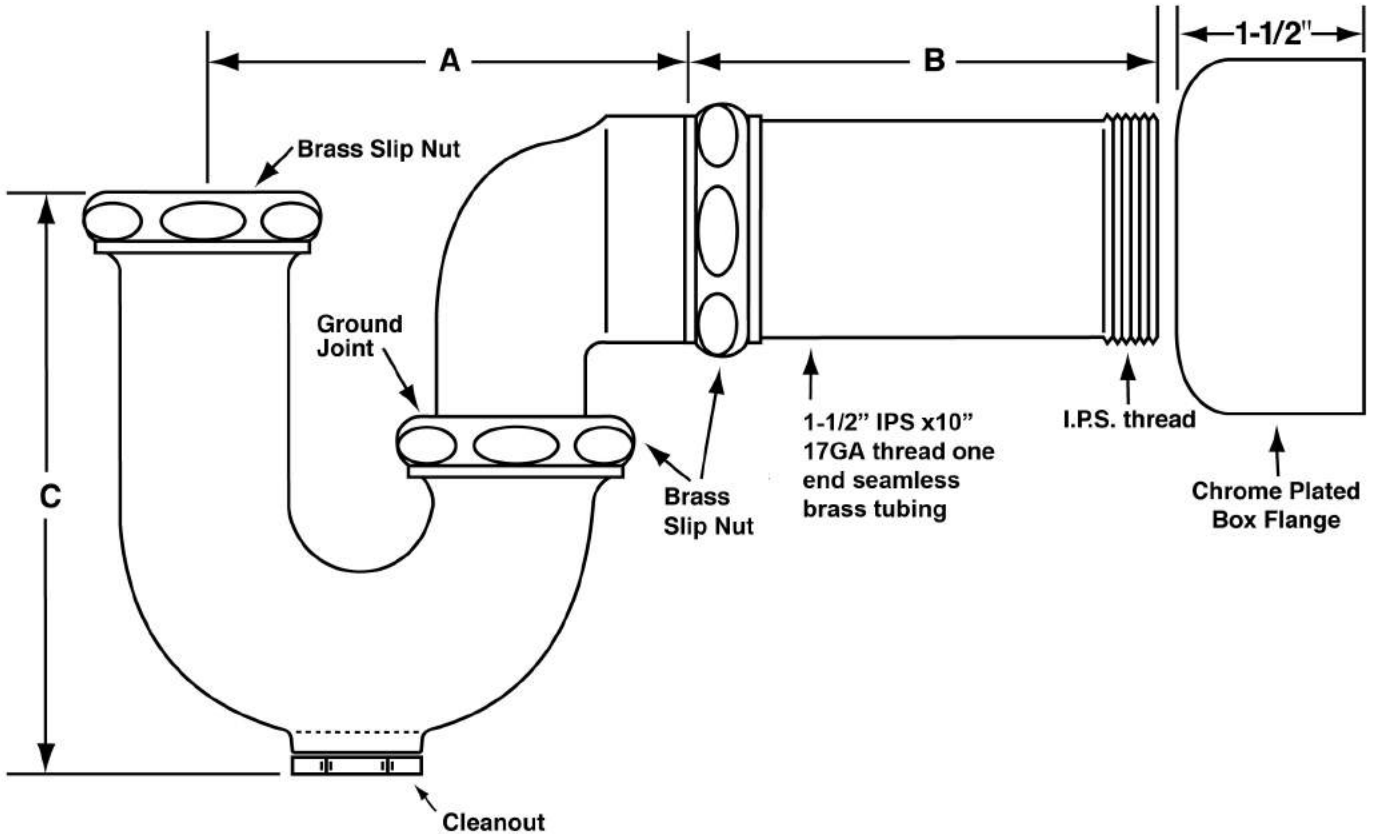

### ROUGHING MEASUREMENTS

NO.	TRAP DIMENSIONS		A	B	C
	INLET	OUTLET			
MCT150UTL17B	1-1/4" x 1-1/2", 1-1/2"	1-1/2" x 10" Slip x I.P.S. 17 G.A. T.O.E. Brass Tube	4-1/4"	10"	5"



ASME A112.18.2/CSA B125.2

### Specifications:

P-Trap shall be 17 GA seamless tubular chrome plated brass with 17 GA utility arm and flange.



#### WARNING:

This product can expose you to chemicals including lead, which is known to the State of California to cause cancer, and birth defects or other reproductive harm. For more information go to [www.P65Warnings.ca.gov](http://www.P65Warnings.ca.gov).





# McGuire Manufacturing Co., Inc.

60 Grandview Court  
Cheshire, Connecticut 06410  
(203) 699-1801 Fax (203) 699-1813  
customerservice@mcguiremfg.com mcguiremfg.com

## PRODUCT SPECIFICATION

**Part No.**

**Options for  
P-Traps**

**Job Name:**

**Submittal Number:**

### CAST BODY P-TRAP OPTIONS

#### WALL BEND OPTIONS-

Add suffix to part number.

- 15** - 15" C to E (1-1/4" and 1-1/2" only)
- 18** - 18" C to E (1-1/4" and 1-1/2" only)
- GJ** - Ground joint wallbend  
Custom sizes available.

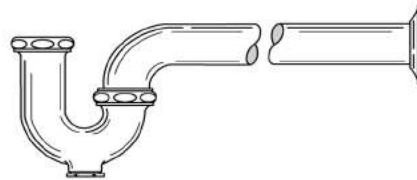

#### FLANGE OPTIONS-

Add suffix to part number.

- F** - Forged Brass, set screw, chrome plated
- DF** - Deep Flange, (bell type) chrome plated brass
- SDF** - Deep Flange, (bell type) chrome plated steel
- B** - Box Flange, chrome plated wrought steel
- BF** - Box Flange, chrome plated brass

#### STANDARD FINISH OPTIONS-

Add suffix to part number.

- C** - Polished Chrome
- S** - Satin Chrome  
Custom finishes available.

Options available for McGuire "Classic" Professional Line only.



**McGuire Manufacturing Co., Inc.**

60 Grandview Court

Cheshire, Connecticut 06410

(203) 699-1801 Fax (203) 699-1813

customerservice@mcguiremfg.com mcguiremfg.com

**PRODUCT SPECIFICATION**

**Part No.**

**V8089C**

**Vandal Resistant Ground  
Joint Swivel P-Trap  
With or Without Cleanout**

**Job Name:**

**Submittal Number:**

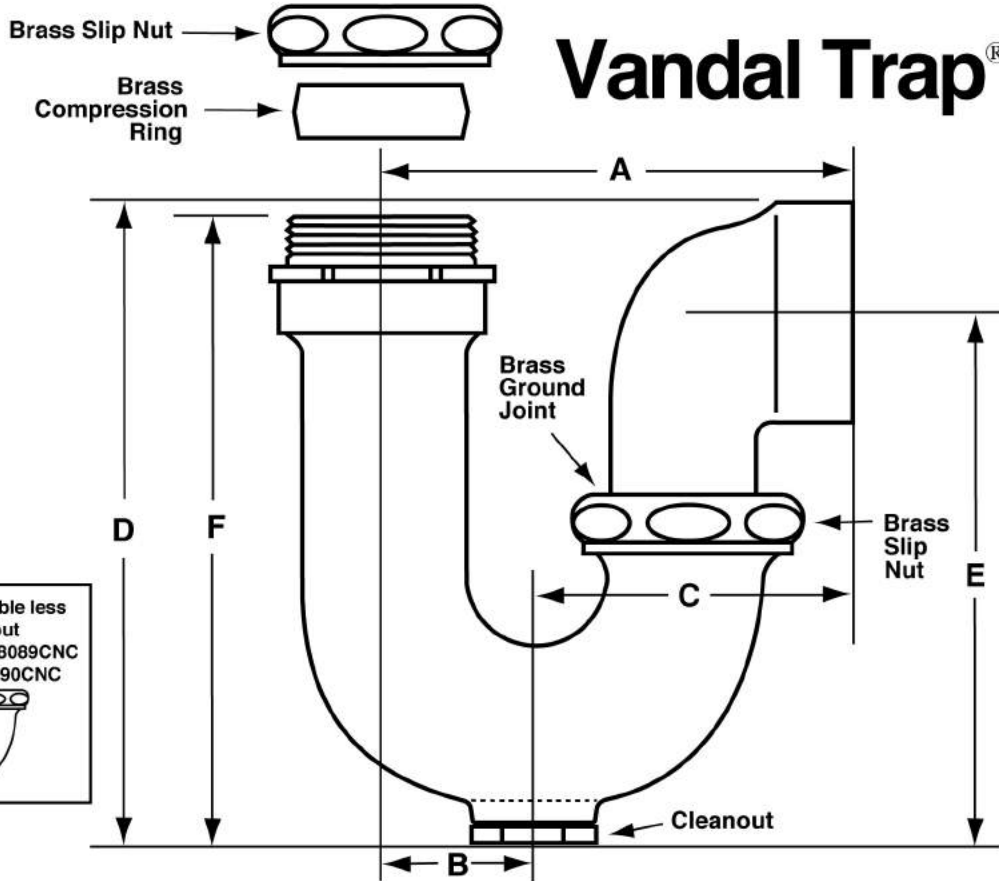

**ROUGHING MEASUREMENTS**

NO.	TRAP DIMENSIONS		A	B	C	D	E	F
	INLET	OUTLET						
V8089C	1-1/2" x 1-1/2"	S.P.S. 1-1/2"	4-1/4"	1-3/8"	2-7/8"	5-3/4"	4-5/8"	5-1/2"

**FED SPEC W.W.P. 541**

**CAST BRASS P TRAP**

**MINIMUM SEAL 2"**

See options and accessories section for details on product variations.



ASME A112.18.2/CSA B125.2

**Specifications:**

Cast brass chrome plated adjustable ground joint swivel P-Trap, vandal resistant, with cleanout. Furnished with cast brass J-Bend with or without cleanout, cast brass slip nuts, heavy brass vandal inlet and cast brass elbow.

Trap shall be certified by CSA or other recognized testing authority and shall bear manufacturer and testing mark.

**WARNING:**

This product can expose you to chemicals including lead, which is known to the State of California to cause cancer, and birth defects or other reproductive harm. For more information go to [www.P65Warnings.ca.gov](http://www.P65Warnings.ca.gov).



**McGuire Manufacturing Co., Inc.**

60 Grandview Court  
 Cheshire, Connecticut 06410  
 (203) 699-1801 Fax (203) 699-1813  
 customerservice@mcguiremfg.com mcguiremfg.com

**Part No.**

**V8089CNC**

**Vandal Resistant Ground  
 Joint Swivel P-Trap  
 With or Without Cleanout**

**PRODUCT SPECIFICATION**

**Job Name:**

**Submittal Number:**

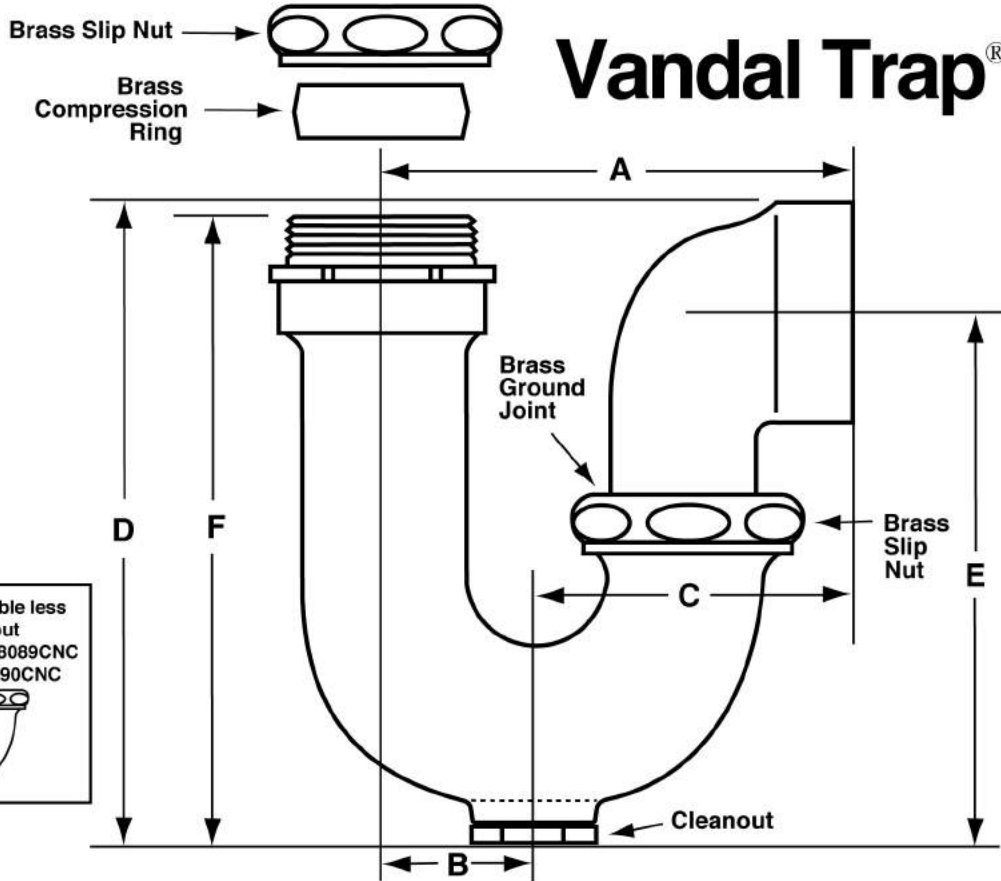

**ROUGHING MEASUREMENTS**

NO.	TRAP DIMENSIONS		A	B	C	D	E	F
	INLET	OUTLET						
V8089CNC	1-1/2" x 1-1/2"	S.P.S. 1-1/2"	4-1/4"	1-3/8"	2-7/8"	5-3/8"	4-1/4"	5-1/8"

**FED SPEC W.W.P. 541  
 CAST BRASS P TRAP  
 MINIMUM SEAL 2"**

See options and accessories section for details on product variations.



ASME A112.18.2/CSA B125.2

**Specifications:**

Cast brass chrome plated adjustable ground joint swivel P-Trap, vandal resistant, with cleanout. Furnished with cast brass J-Bend with or without cleanout, cast brass slip nuts, heavy brass vandal inlet and cast brass elbow. Trap shall be certified by CSA or other recognized testing authority and shall bear manufacturer and testing mark.



**WARNING:**

This product can expose you to chemicals including lead, which is known to the State of California to cause cancer, and birth defects or other reproductive harm. For more information go to [www.P65Warnings.ca.gov](http://www.P65Warnings.ca.gov).



**McGuire Manufacturing Co., Inc.**

60 Grandview Court

Cheshire, Connecticut 06410

(203) 699-1801 Fax (203) 699-1813

customerservice@mcguiremfg.com mcguiremfg.com

**PRODUCT SPECIFICATION**

**Part No.**

**V8090C**

**Vandal Resistant Ground  
Joint Swivel P-Trap  
With or Without Cleanout**

**Job Name:**

**Submittal Number:**

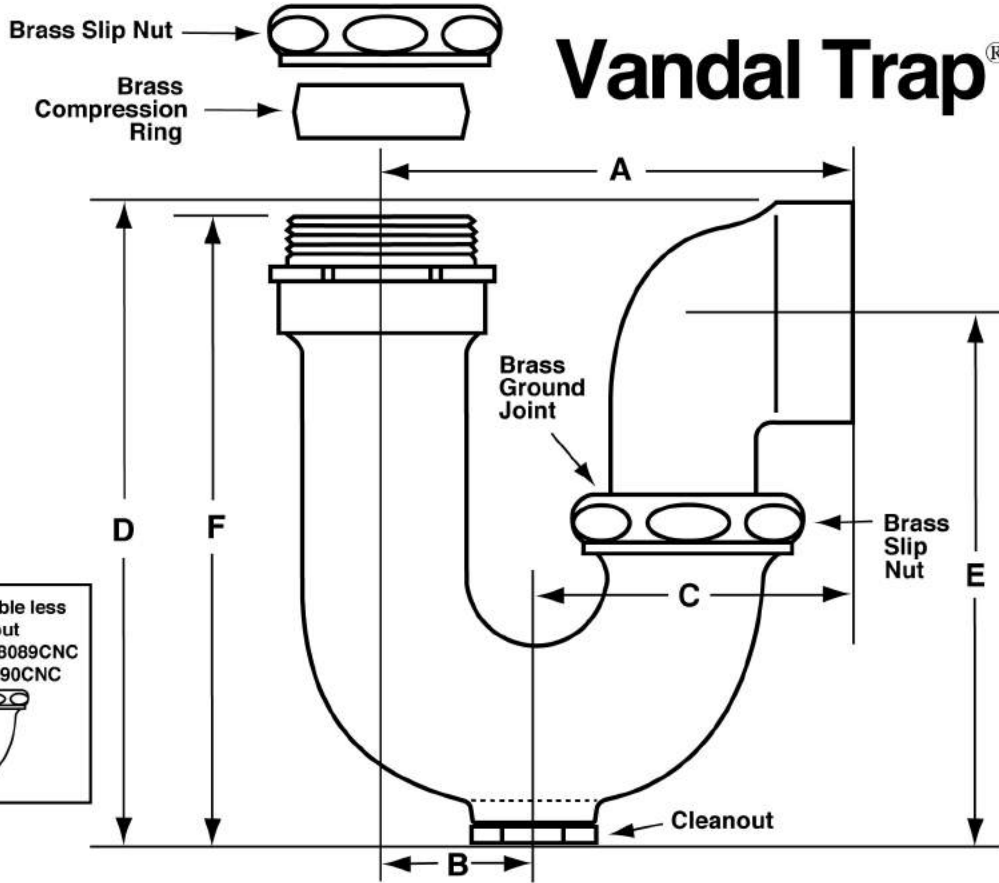

**ROUGHING MEASUREMENTS**

NO.	TRAP DIMENSIONS		A	B	C	D	E	F
	INLET	OUTLET						
V8090C	1-1/4" x 1-1/2"	S.P.S. 1-1/2"	4-1/4"	1-3/8"	2-7/8"	5-3/4"	4-5/8"	5-1/2"

**FED SPEC W.W.P. 541**

**CAST BRASS P TRAP**

**MINIMUM SEAL 2"**

See options and accessories section for details on product variations.



ASME A112.18.2/CSA B125.2

**Specifications:**

Cast brass chrome plated adjustable ground joint swivel P-Trap, vandal resistant, with cleanout. Furnished with cast brass J-Bend with or without cleanout, cast brass slip nuts, heavy brass vandal inlet and cast brass elbow.

Trap shall be certified by CSA or other recognized testing authority and shall bear manufacturer and testing mark.



**WARNING:**

This product can expose you to chemicals including lead, which is known to the State of California to cause cancer, and birth defects or other reproductive harm. For more information go to [www.P65Warnings.ca.gov](http://www.P65Warnings.ca.gov).



**McGuire Manufacturing Co., Inc.**

60 Grandview Court

Cheshire, Connecticut 06410

(203) 699-1801 Fax (203) 699-1813

customerservice@mcguiremfg.com mcguiremfg.com

**PRODUCT SPECIFICATION**

**Part No.**

**V8090CNC**

**Vandal Resistant Ground  
Joint Swivel P-Trap  
With or Without Cleanout**

**Job Name:**

**Submittal Number:**

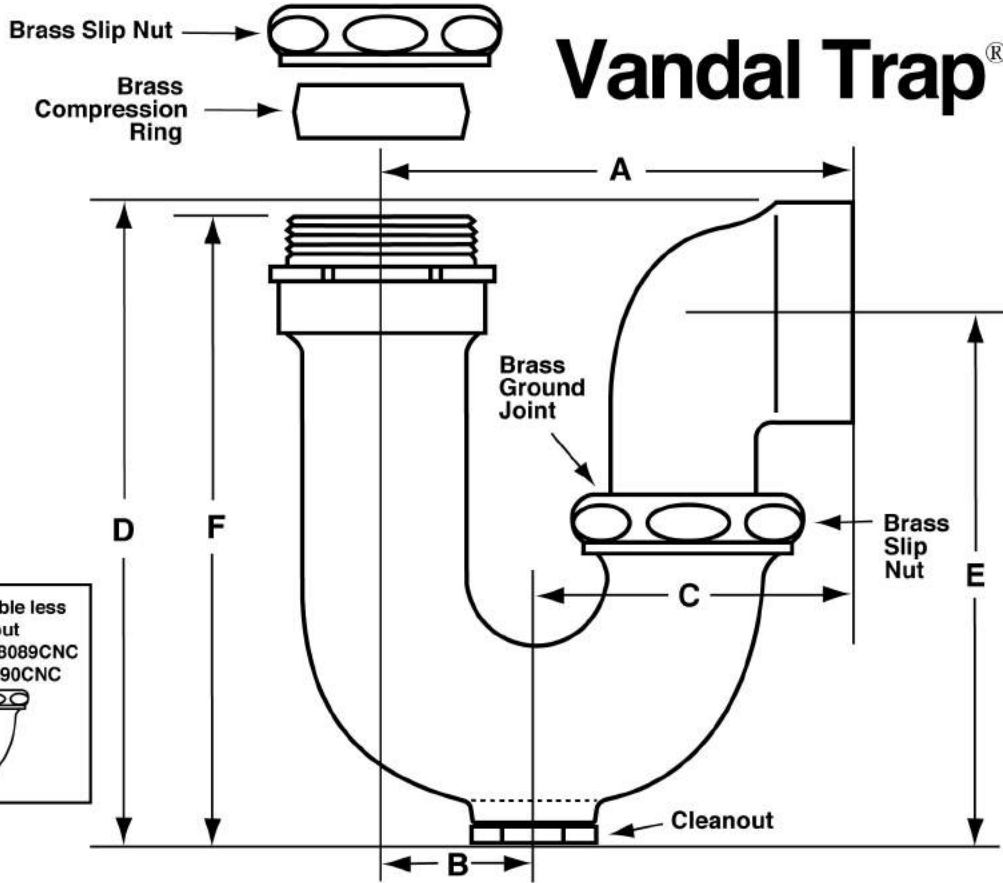

**ROUGHING MEASUREMENTS**

NO.	TRAP DIMENSIONS		A	B	C	D	E	F
	INLET	OUTLET						
V8090CNC	1-1/4" x 1-1/2"	S.P.S. 1-1/2"	4-1/4"	1-3/8"	2-7/8"	5-3/8"	4-1/4"	5-1/8"

**FED SPEC W.W.P. 541**

**CAST BRASS P TRAP**

**MINIMUM SEAL 2"**

See options and accessories section for details on product variations.



ASME A112.18.2/CSA B125.2

**Specifications:**

Cast brass chrome plated adjustable ground joint swivel P-Trap, vandal resistant, with cleanout. Furnished with cast brass J-Bend with or without cleanout, cast brass slip nuts, heavy brass vandal inlet and cast brass elbow.

Trap shall be certified by CSA or other recognized testing authority and shall bear manufacturer and testing mark.



**WARNING:**

This product can expose you to chemicals including lead, which is known to the State of California to cause cancer, and birth defects or other reproductive harm. For more information go to [www.P65Warnings.ca.gov](http://www.P65Warnings.ca.gov).



**McGuire Manufacturing Co., Inc.**

60 Grandview Court  
 Cheshire, Connecticut 06410  
 (203) 699-1801 Fax (203) 699-1813  
 customerservice@mcguiremfg.com mcguiremfg.com

**Part No.**  
**V8902C**  
**Vandal Resistant P-Trap**  
**With or Without Cleanout**

**PRODUCT SPECIFICATION**

**Job Name:**

**Submittal Number:**

**Vandal Trap®**

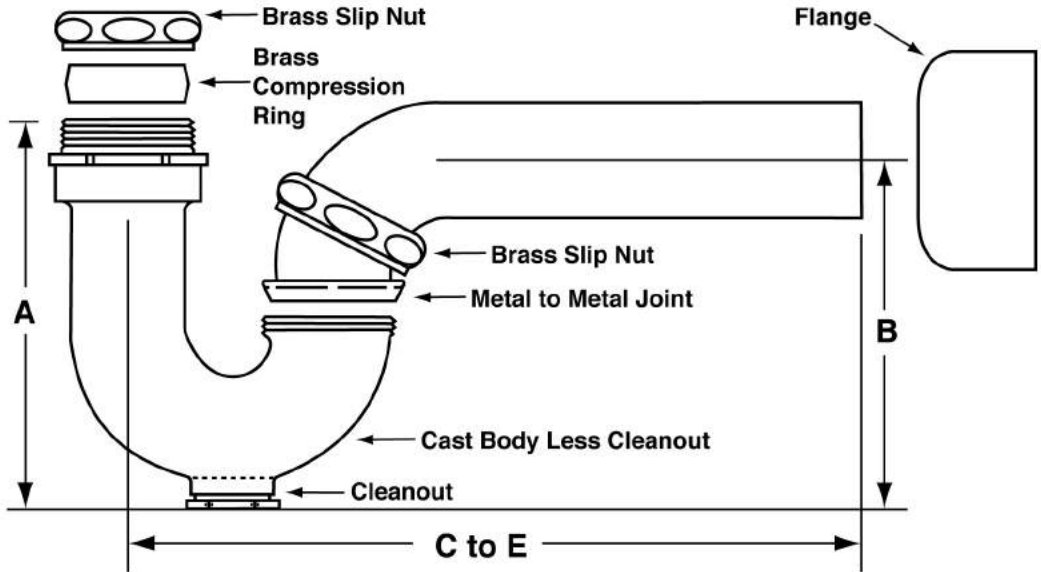

ROUGHING MEASUREMENTS				
NO.	TRAP DIMENSIONS	A	B	C to E
V8902C	1-1/4" Inlet x 1-1/2" - 17 G.A.	6"	4-3/4"	12"

**FED SPEC W.W.P. 541**  
**CAST BRASS P TRAP**  
**MINIMUM SEAL 2"**



See options and accessories section for details on product variations.

ASME A112.18.2/CSA B125.2

**Specifications:**

Cast brass chrome plated adjustable P-Trap, vandal resistant, with cleanout. Furnished with polished and chrome plated cast J-Bend without cleanout, chrome plated brass slip nuts, heavy brass vandal inlet and outlet connections. Trap shall be certified by CSA or other recognized testing authority. P-Trap shall bear manufacturer and testing mark.



**WARNING:**

This product can expose you to chemicals including lead, which is known to the State of California to cause cancer, and birth defects or other reproductive harm. For more information go to [www.P65Warnings.ca.gov](http://www.P65Warnings.ca.gov).



**McGuire Manufacturing Co., Inc.**

60 Grandview Court  
 Cheshire, Connecticut 06410  
 (203) 699-1801 Fax (203) 699-1813  
 customerservice@mcguiremfg.com mcguiremfg.com

**Part No.**  
**V8902CNC**  
**Vandal Resistant P-Trap**  
**With or Without Cleanout**

**PRODUCT SPECIFICATION**

**Job Name:** \_\_\_\_\_ **Submittal Number:** \_\_\_\_\_

**Vandal Trap®**

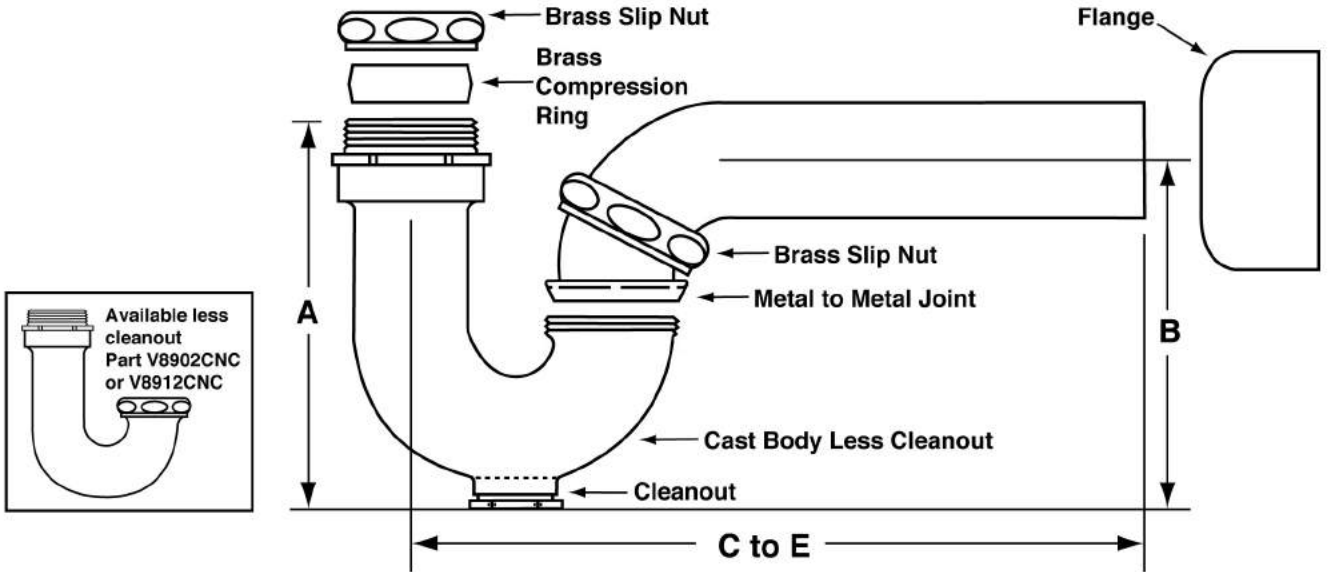

ROUGHING MEASUREMENTS				
NO.	TRAP DIMENSIONS	A	B	C to E
V8902CNC	1-1/4" Inlet x 1-1/2" - 17 G.A.	5-3/4"	4-1/2"	12"

**FED SPEC W.W.P. 541**  
**CAST BRASS P TRAP**  
**MINIMUM SEAL 2"**



See options and accessories section for details on product variations.

ASME A112.18.2/CSA B125.2

**Specifications:**

Cast brass chrome plated adjustable P-Trap, vandal resistant, with cleanout. Furnished with polished and chrome plated cast J-Bend without cleanout, chrome plated brass slip nuts, heavy brass vandal inlet and outlet connections. Trap shall be certified by CSA or other recognized testing authority. P-Trap shall bear manufacturer and testing mark.

**WARNING:**

This product can expose you to chemicals including lead, which is known to the State of California to cause cancer, and birth defects or other reproductive harm. For more information go to [www.P65Warnings.ca.gov](http://www.P65Warnings.ca.gov).



**McGuire Manufacturing Co., Inc.**

60 Grandview Court  
 Cheshire, Connecticut 06410  
 (203) 699-1801 Fax (203) 699-1813  
 customerservice@mcguiremfg.com mcguiremfg.com

**Part No.**  
**V8912C**  
**Vandal Resistant P-Trap**  
**With or Without Cleanout**

**PRODUCT SPECIFICATION**

**Job Name:**

**Submittal Number:**

**Vandal Trap®**

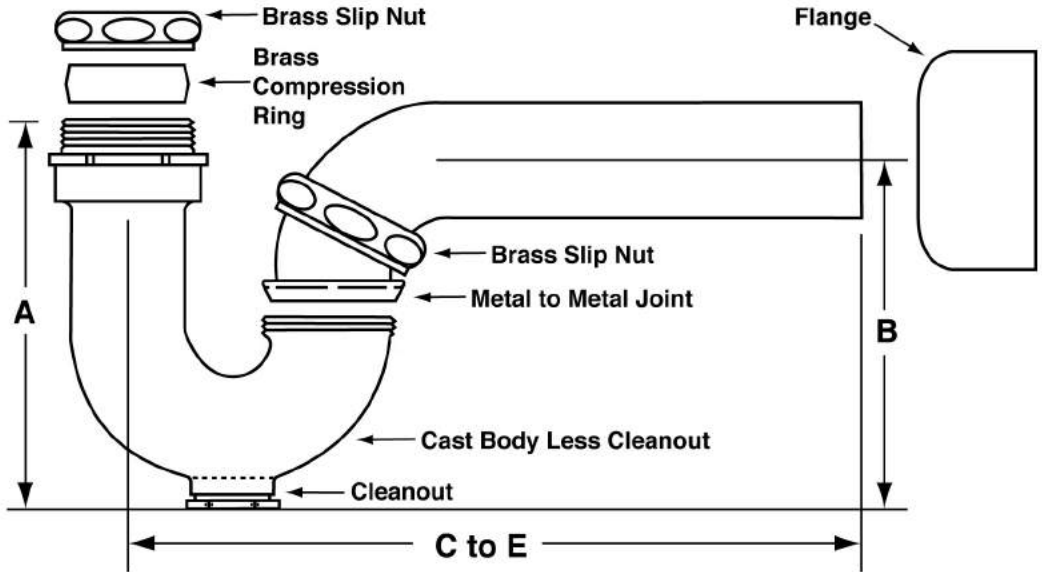

ROUGHING MEASUREMENTS				
NO.	TRAP DIMENSIONS	A	B	C to E
V8912C	1-1/2" Inlet x 1-1/2" - 17 G.A.	6"	4-3/4"	12"

**FED SPEC W.W.P. 541**  
**CAST BRASS P TRAP**  
**MINIMUM SEAL 2"**



See options and accessories section for details on product variations.

ASME A112.18.2/CSA B125.2

**Specifications:**

Cast brass chrome plated adjustable P-Trap, vandal resistant, with cleanout. Furnished with polished and chrome plated cast J-Bend without cleanout, chrome plated brass slip nuts, heavy brass vandal inlet and outlet connections. Trap shall be certified by CSA or other recognized testing authority. P-Trap shall bear manufacturer and testing mark.



**WARNING:**

This product can expose you to chemicals including lead, which is known to the State of California to cause cancer, and birth defects or other reproductive harm. For more information go to [www.P65Warnings.ca.gov](http://www.P65Warnings.ca.gov).





**McGuire Manufacturing Co., Inc.**

60 Grandview Court  
 Cheshire, Connecticut 06410  
 (203) 699-1801 Fax (203) 699-1813  
 customerservice@mcguiremfg.com mcguiremfg.com

**Part No.**

**V8912CNC**

**Vandal Resistant P-Trap  
 With or Without Cleanout**

**PRODUCT SPECIFICATION**

**Job Name:**

**Submittal Number:**

**Vandal Trap®**

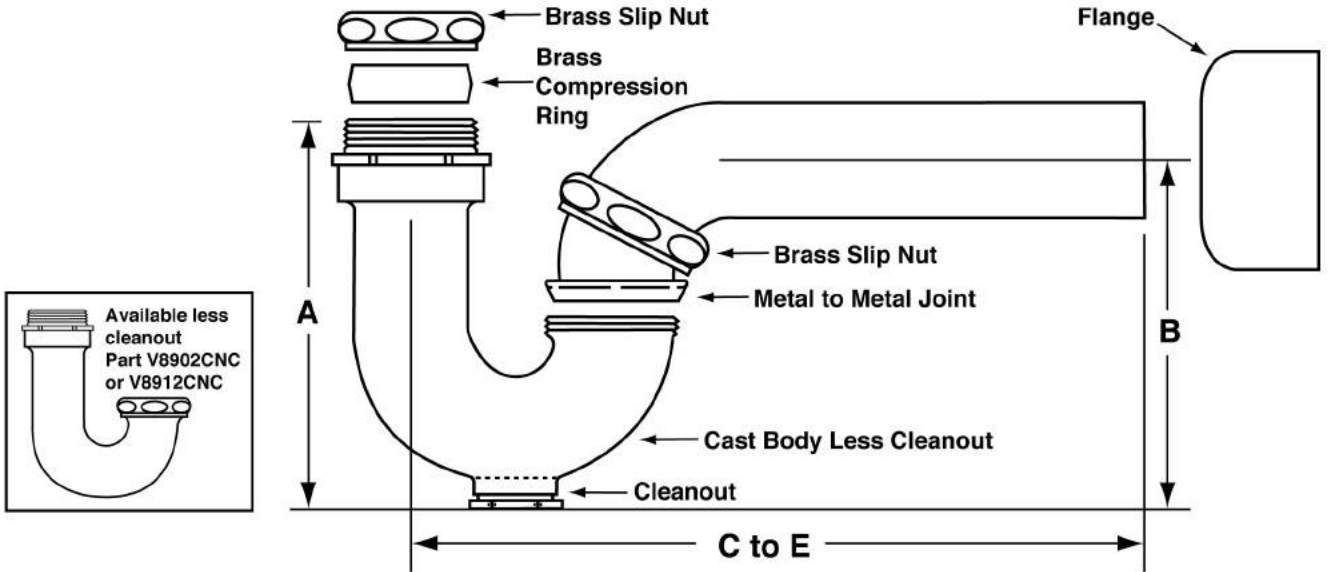

ROUGHING MEASUREMENTS				
NO.	TRAP DIMENSIONS	A	B	C to E
V8912CNC	1-1/2" Inlet x 1-1/2" - 17 G.A.	5-3/4"	4-1/2"	12"

**FED SPEC W.W.P. 541  
 CAST BRASS P TRAP  
 MINIMUM SEAL 2"**



See options and accessories section for details on product variations.

ASME A112.18.2/CSA B125.2

**Specifications:**

Cast brass chrome plated adjustable P-Trap, vandal resistant, with cleanout. Furnished with polished and chrome plated cast J-Bend without cleanout, chrome plated brass slip nuts, heavy brass vandal inlet and outlet connections. Trap shall be certified by CSA or other recognized testing authority. P-Trap shall bear manufacturer and testing mark.

**WARNING:**

This product can expose you to chemicals including lead, which is known to the State of California to cause cancer, and birth defects or other reproductive harm. For more information go to [www.P65Warnings.ca.gov](http://www.P65Warnings.ca.gov).